

UNENE Graduate Course Reactor Thermal-Hydraulics Design

McMaster University
Whitby

March 1-2, March 15-16,
April 5-6, April 19, 2008

Heat Transport System

Dr. Nik Popov

Outline

- Reactor heat generation parameters
- Reactor heat balance
- Steam generator
- Primary side flow
- Secondary side flow
- Approximate solution
- Heat balance for CANDU 6
- Steam generator with preheater (analytical solution)
- Steam generator with preheater (numerical solution)

Reactor Heat Balance

- Heat is generated by nuclear fission, transferred to a moving heat transport medium, and carried by this medium to the steam generators for steam production
- What is heat balance in the reactor
 - energy out of the reactor equals the energy going in plus the reactor energy generation

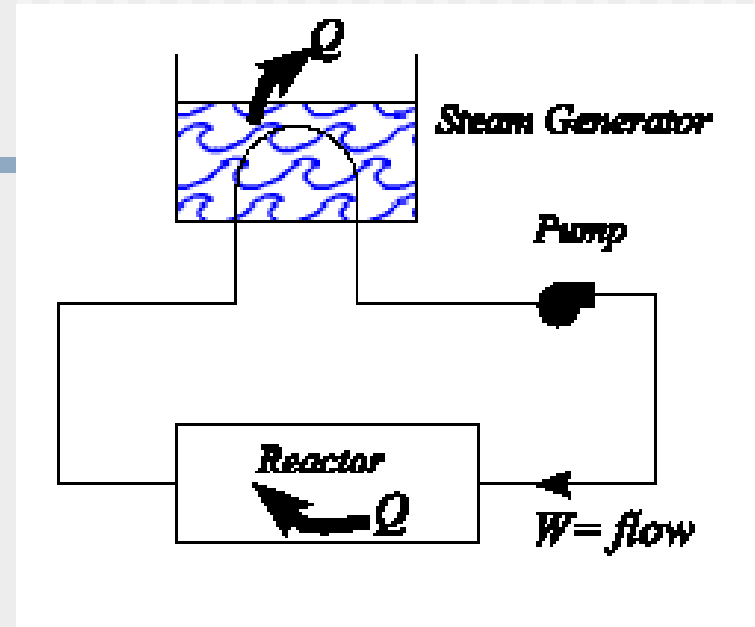

$$Q = W (h_o - h_i) \quad (2)$$

where W = coolant mass flowrate (kg/s);
 h_o = core exit enthalpy (kJ/kg);
 h_i = core inlet enthalpy (kJ/kg);
 Q = reactor power transferred to the coolant (kJ/s or kW).

Reactor Heat Generation Parameters

- Volumetric energy (heat) generation rate, q''' (kW/m³)
 - Used by reactor designers as indication of design compactness
- Surface heat flux, q'' (kW/m²)
 - Used by thermal designers as indication of thermal margin
- Linear heat generation rate, or power rating, q' (kW/m)
 - Used by fuel designers as indication of fuel thermal stress
- Core power, Q (kW)
- Core power density, Q''' (kW/m³)
 - Figure of merit for core thermal performance

Concept of Critical Heat Flux Ratio

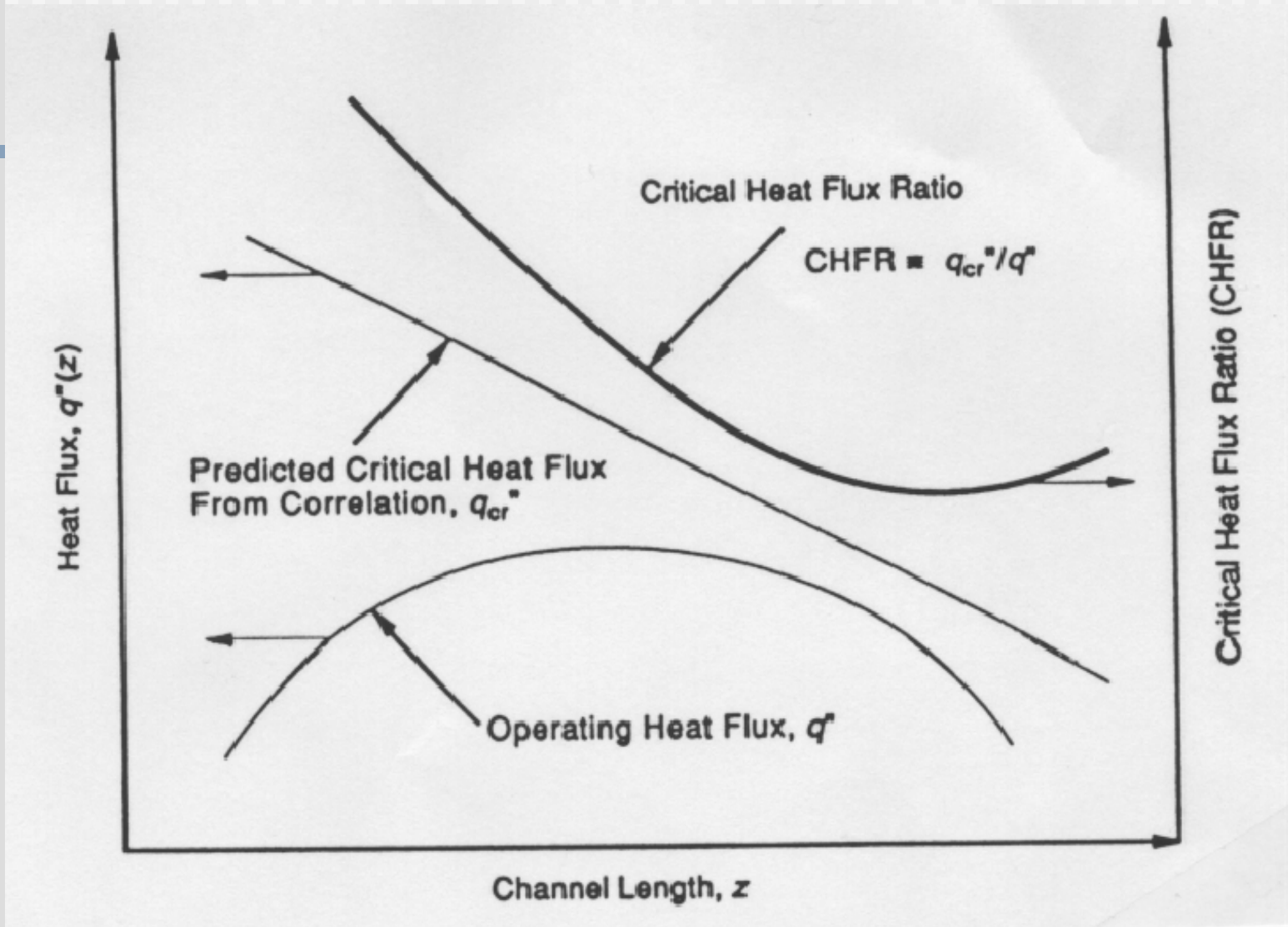

Concept of Core Thermal Margins

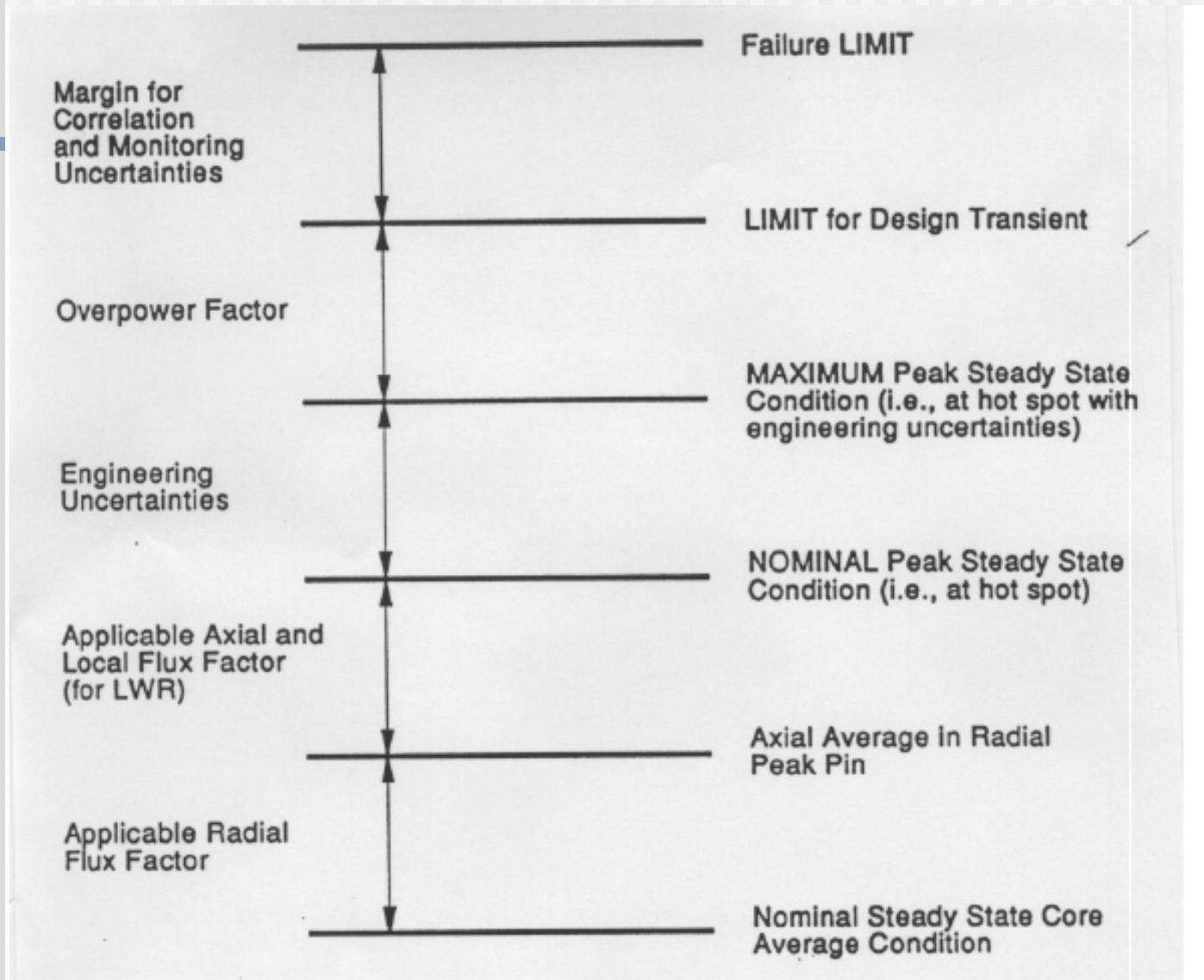

Steam Generator Heat Balance

- The heat transfer at any point in the steam generator is given by Fourier's law

$$dQ = U (T_p - T_s) dA$$

where U = overall heat transfer coefficient ($\text{kJ/m}^2 \cdot ^\circ\text{C}$),
 A = heat transfer area (m^2),
 T_p = primary (D_2O) side temperature ($^\circ\text{C}$)
 T_s = secondary side (H_2O) temperature ($^\circ\text{C}$).

Thus the total heat transfer is

$$Q = \int_Q dQ = \int_A U (T_p - T_s) dA_s$$

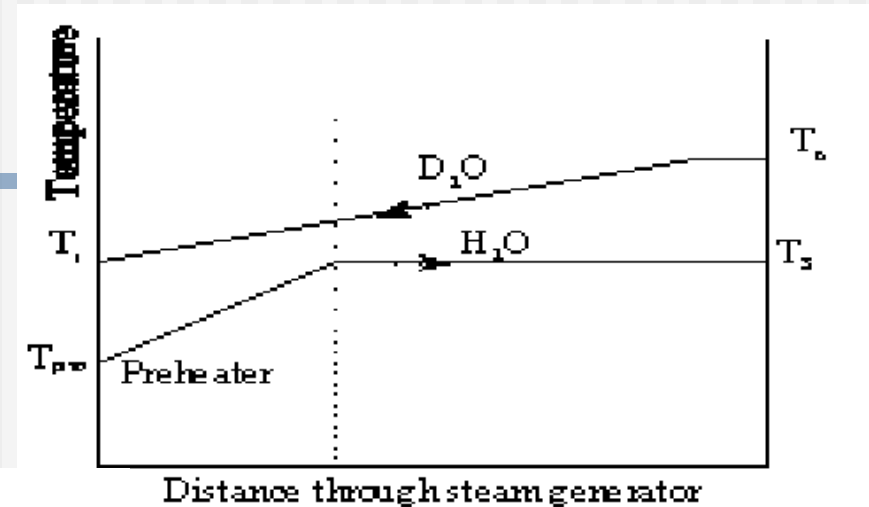

Steam Generator Heat Balance

- No pre-heater region

$$Q = UA \frac{(T_{OUT} + T_{IN})}{2} - UAT_s$$

$$Q = UA \left(\frac{T_o + T_i}{2} - T_s \right)$$

$$h \approx C_p T + \text{CONSTANT}$$

$$Q = \frac{UA}{C_p} \left[\frac{h_o + h_i}{2} - h_s \right]$$

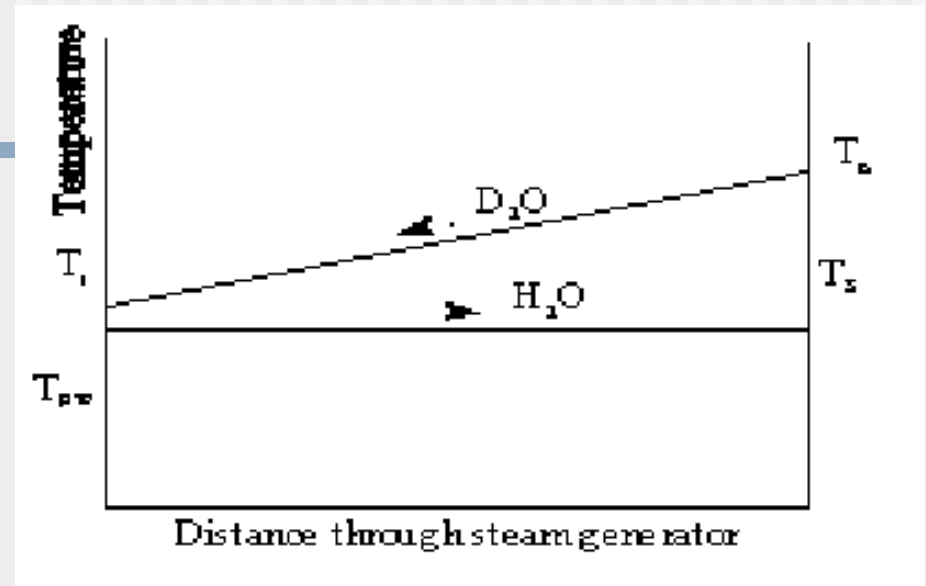

Primary Side Flow

- The primary side flow is determined by a balance between the head generated by the primary pumps and the circuit head losses due to friction.

$$\Delta P_{pump} = \Delta P_{circuit}$$

$$\Delta P_{pump} = A_0 + A_1 W + A_2 W^2 + \dots$$

$$\Delta P_{circuit} = K W^2$$

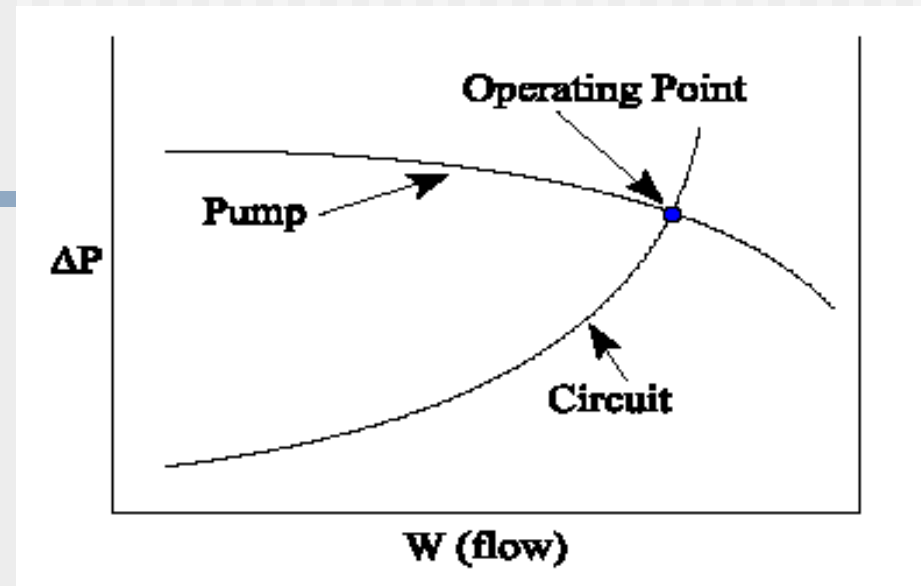

Primary Side Pumps

- Primary pumps – vital component in the reactor Heat Transport System (HTS)
 - Primary function to provide continuous cooling of the reactor core in normal operation, transient and during reactor shutdown
- Accurate prediction of pump performance includes specification of its head (H), torque (τ), discharge or volumetric flow rate (Q), and rotor speed (ω)
- The pump characteristics are described by the specific relationships, called homologous relationships

$$\frac{H_1}{\omega_1^2} = \frac{H_2}{\omega_2^2}$$

$$\frac{Q_1}{\omega_1} = \frac{Q_2}{\omega_2}$$

$$\frac{H_1}{Q_1^2} = \frac{H_2}{Q_2^2}$$

$$\frac{H_1}{\omega^2} = a_1 + a_2 \left(\frac{Q}{\omega} \right) + a_3 \left(\frac{Q}{\omega} \right)^2$$

$$h \equiv \frac{H}{H_R}; \quad v \equiv \frac{Q}{Q_R}; \quad \alpha \equiv \frac{\omega}{\omega_R}; \quad \beta \equiv \frac{\tau}{\tau_R}$$

Primary Side Pumps

- One of the most important objectives of the HTS flow design is to make sure that the pump suction pressure does not fall below the Net Positive Suction Head Required (NPSHR)
- In order for a pump to deliver its rated output it is necessary that the absolute pressure (including the velocity head $V^2/2g$) of the fluid at the pump inlet exceeds the vapour pressure by an amount sufficient to overcome any entrance or frictional losses between the point of entry into the pump and the impeller
- NPSHR (required) is determined by the pump manufacturer and is a function of both pump speed and pump capacity

Primary Side Pumps

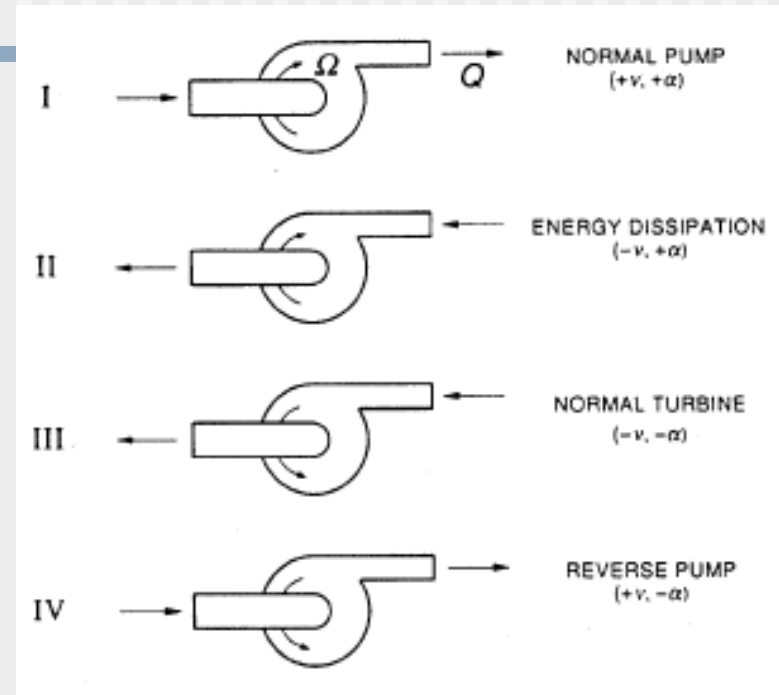
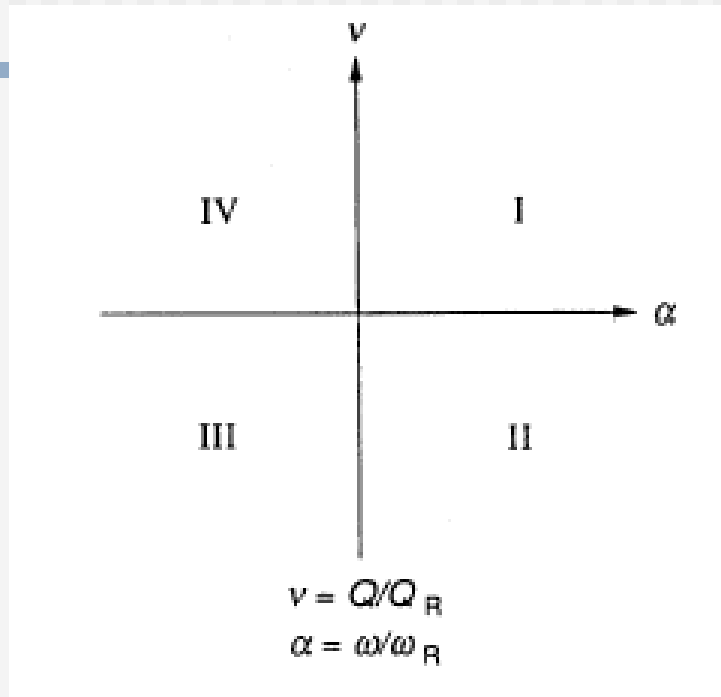

Secondary Side Flow

- The secondary side steam flow can be calculated by an energy balance on the secondary side of the boiler

$$\underline{Q} = W_{steam} (h_{steam} - h_{feedwater})$$

$$W_{steam} = \frac{\underline{Q}}{(h_{steam} - h_{feedwater})}$$

Approximate Solution

- Energy balance
 - Reactor core
 - Steam generator
 - Momentum balance around the circuit

$$h_o = \frac{Q}{W} + h_i$$

$$\frac{Q}{W} = \frac{UA}{C_p W} \left[\frac{Q}{2W} + h_i - h_s \right] = \frac{UA}{W} \left[\frac{Q}{2C_p W} + T_i - T_s \right]$$

$$h_i = \frac{Q}{W} \left[\frac{C_p W}{UA} - \frac{1}{2} \right] + h_s = \frac{QC_p}{UA} + h_s - \frac{Q}{2W}$$

$$T_i = \frac{Q}{W} \left[\frac{W}{UA} - \frac{1}{2C_p} \right] + T_s$$

$$Q = W (h_o - h_i)$$

$$Q = \frac{UA}{C_p} \left[\frac{h_o + h_i}{2} - h_s \right] = UA \left[\frac{T_o - T_i}{2} - T_s \right]$$

$$\Delta P_{pump} = \Delta P_{circuit}$$

$$Q = W_{steam} (h_{steam} - h_{feedwater})$$

Approximate Solution

$$T_o = \frac{Q}{W} \left[\frac{W}{UA} + \frac{1}{2C_p} \right] + T_s$$

$$\begin{aligned} h_o &= \frac{Q}{W} + h_i = \frac{Q}{W} + \frac{Q}{W} \left[\frac{C_p W}{UA} - \frac{1}{2} \right] + h_s \\ &= \frac{Q}{W} \left[\frac{C_p W}{UA} + \frac{1}{2} \right] + h_s \end{aligned}$$

$$h_{aver} = \frac{h_o + h_i}{2} = \frac{Q}{W} \left(\frac{C_p W}{UA} \right) + h_s = \left(\frac{QC_p}{UA} \right) + h_s$$

$$T_{aver} = \frac{T_o + T_i}{2} = \frac{Q}{UA} + T_s$$

$$\begin{aligned} T_o - T_{aver} &= \frac{Q}{W} \left(\frac{W}{UA} + \frac{1}{2C_p} \right) + T_s - \frac{Q}{W} \frac{W}{UA} - T_s \\ &= \frac{Q}{2WC_p} \end{aligned}$$

$$T_{aver} - T_i = \frac{Q}{2C_p W}$$

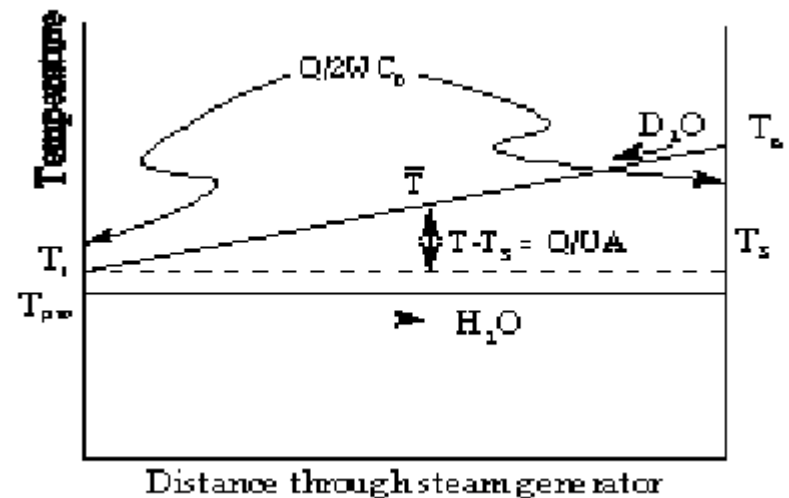

Heat Balance for CANDU 6

$$Q \approx 2000 \text{ MW(th)} = 2 \times 10^6 \text{ kW(th)} \text{ (given)}$$

$$W \approx 8000 \text{ kg/s total core flow (guessed)}$$

$$T_s \approx 265 \text{ }^\circ\text{C (given)} \quad \rightarrow h_s \approx 1150 \text{ kJ/kg}$$

$$C_p \approx 5 \text{ kJ/kg }^\circ\text{C (guessed)}$$

$$U \approx 5 \text{ kJ/s }^\circ\text{C m}^2 \quad \rightarrow (C_p W / UA) \approx 0.625$$

$$A \approx 3200 \text{ m}^2 / \text{ steam generator}$$

$$P_{\text{ROH}} = 10 \text{ MPa (given)}$$

$$W = \frac{Q}{2\left(\frac{QC_p}{UA} + h_s - h_i\right)}$$

$$\frac{\delta W}{\delta h_i} = \frac{Q}{2\left(\frac{QC_p}{UA} + h_s - h_i\right)^2} = \frac{Q}{2\left(\frac{Q}{2W}\right)^2} = \frac{2W^2}{Q}$$

$$\frac{\delta\left(\frac{W}{W_o}\right)}{\delta\left(\frac{h_i}{h_{io}}\right)} = 9.0$$

Steam Generator with Pre-Heater (Simple Analytical Solution)

$$Q = W C_p (T_o - T_i)$$

where:

Q = reactor power
= steam generator power
 C_p = D_2O heat capacity
= constant
 T_o = ROH temperature
 T_i = RIH temperature

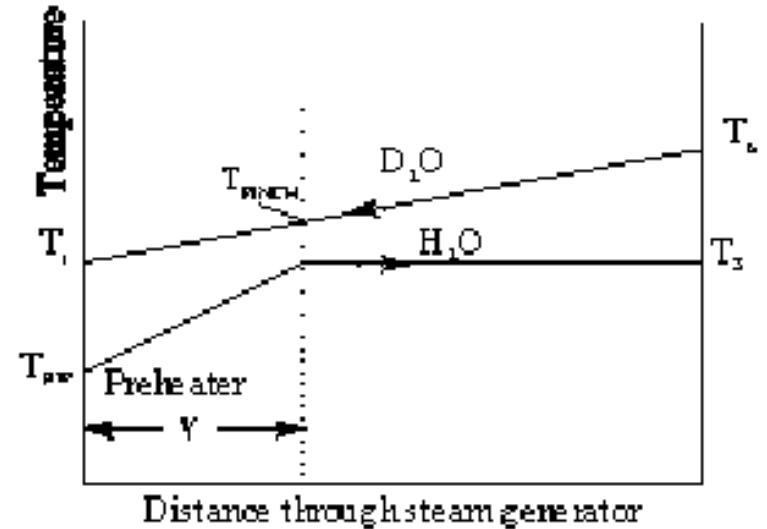

$$dQ = U dA (T_{PRIMARY} - T_{SECONDARY})$$

where:

U = overall heat transfer coefficient
 dA = incremental heat transfer area
 $T_{PRIMARY}$ = temperature of D_2O in S.G. tubes
 $T_{SECONDARY}$ = temperature of H_2O in S.G. shell.

Steam Generator with Pre-Heater (Simple Analytical Solution)

$$Q = UA(1 - \gamma) \left[\frac{(T_o + T_{PINCH})}{2} - T_s \right] + UA\gamma \left[\frac{(T_i + T_{PINCH})}{2} - \frac{(T_s + T_{FW})}{2} \right]$$

γ = the fraction of the steam generator associated with preheating the feedwater

T_{PINCH} = D₂O temperature at the pinch point

T_s = temperature of saturated H₂O

T_{FW} = feedwater inlet temperature.

$$\begin{aligned} T_{PINCH} &= T_i + \gamma (T_o - T_i) \\ &= T_i + \gamma \frac{Q}{C_p W} \end{aligned}$$

$$Q = UA \left[\left(\frac{T_o + T_i}{2} \right) - T_s + \frac{\gamma}{2} (T_s - T_{FW}) \right]$$

$$T_o = \frac{Q}{W C_p} + T_i$$

Steam Generator with Pre-Heater (Simple Analytical Solution)

$$T_i = \frac{Q}{WC_p} \left[\frac{WC_p}{UA} - \frac{1}{2} \right] - \frac{\gamma}{2} [T_s - T_{FW}] + T_s$$

$$T_o = \frac{Q}{WC_p} \left[\frac{WC_p}{UA} + \frac{1}{2} \right] - \frac{\gamma}{2} [T_s - T_{FW}] + T_s$$

$$T_o = \frac{Q}{WC_p} \left[\frac{WC_p}{UA} + \frac{1}{2} \right] - \frac{\gamma}{2} [T_s - T_{FW}] + T_s$$

$$Q_{\text{PREHEATER}} = UA \gamma \left[\left(\frac{T_i + T_{\text{PINCH}}}{2} \right) - \frac{(T_s + T_{FW})}{2} \right]$$

$$\gamma = \frac{W_{FW} C_{\text{PH}_2\text{O}} (T_{FW_{\text{SAT}}} - T_{FW})}{UA \left[\frac{(T_i + T_{\text{PINCH}})}{2} - \frac{(T_s + T_{FW})}{2} \right]}$$

Steam Generator with Pre-Heater (Simple Analytical Solution)

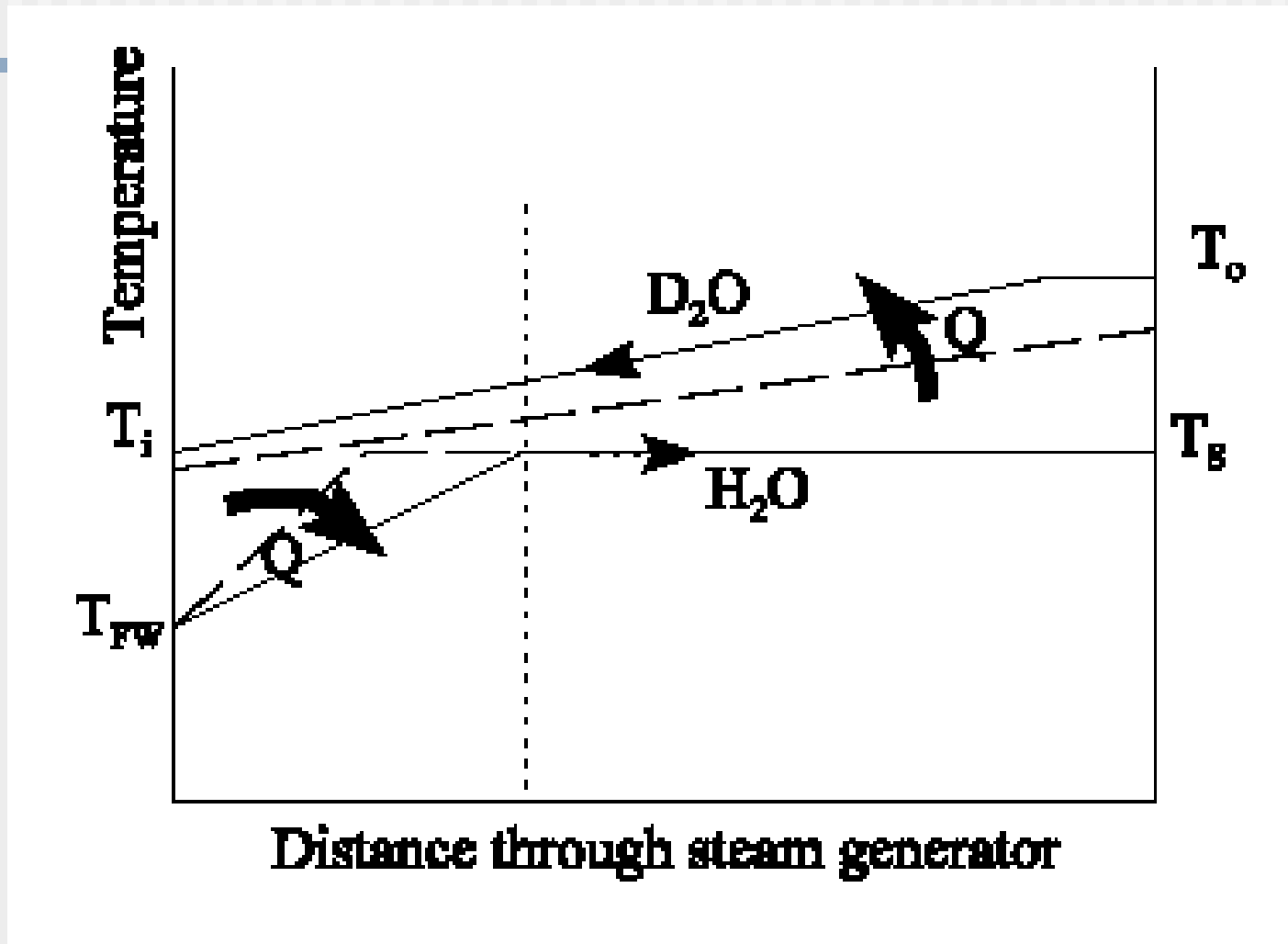

Steam Generator with Pre-Heater (Numerical Solution)

$$dq = U dA (T_p - T_s)$$

$$W_s \times dh_s = dq$$

$$W_p \times dh_p = -dq$$

$$dT_p = -\frac{U dA (T_p - T_s)}{C_p W_p}$$

$$dh = C_p dT$$

$$dT_s = \frac{U dA (T_p - T_s)}{C_p W_s}$$

$$T_{p,j+1} = T_{p,j} + \frac{U A}{C_p N W_p} (T_{p,j} - T_{s,j})$$

$$T_{s,j+1} = T_{s,j} + \frac{U A}{C_p N W_s} (T_{p,j} - T_{s,j})$$

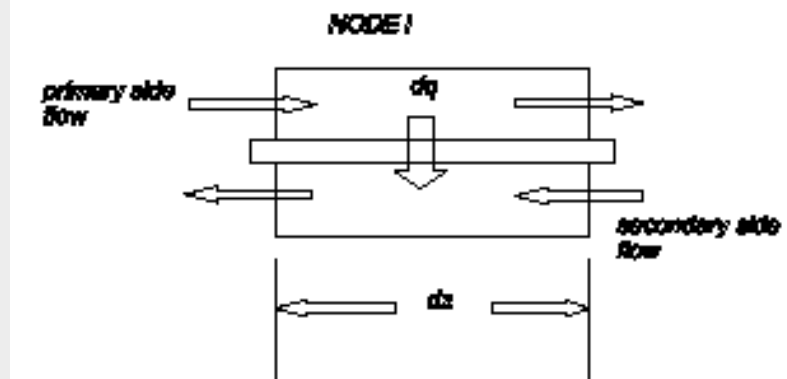
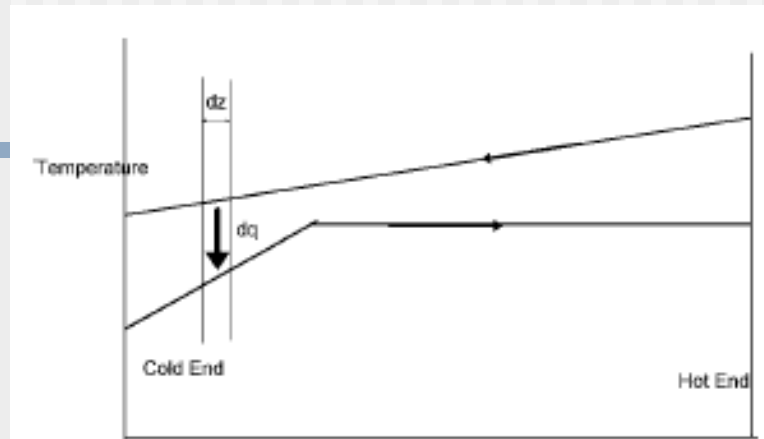

Questions?
