

UNENE Graduate Course Reactor Thermal-Hydraulics Design

McMaster University
Whitby

March 1-2, March 15-16,
April 5-6, April 19, 2008

Design Evolution

Dr. Nik Popov

CANDU Product History

CANDU 9

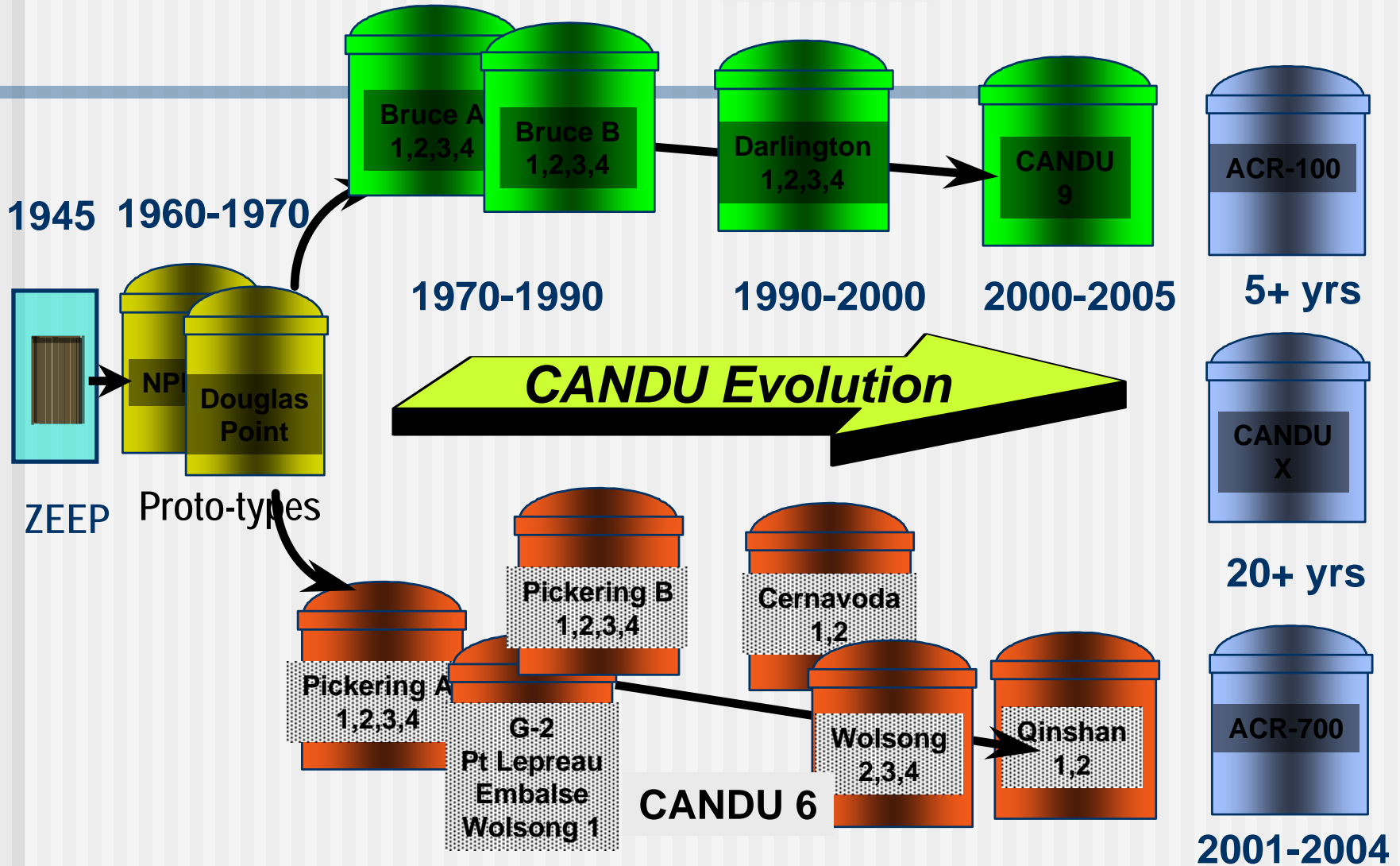

TH Design Evolution

- Heat Transport System

- Higher reliability
- Better maintainability
- Reduction of dose to operating staff
- Increase of power output
- Examples
 - NPD – 100 valves per MW
 - Darlington – less than 1 valve per MW

TH Design Evolution

- Steam Generator
 - Size and power increased
 - Tube material – Inconel 600 > Incaloy 800
- Heat Transport Pumps
 - Maintainability – interchangeable sub-assemblies
 - Shielding
 - Flywheels – from solid to laminations to reduce propagation of defects

TH Design Evolution - SGs

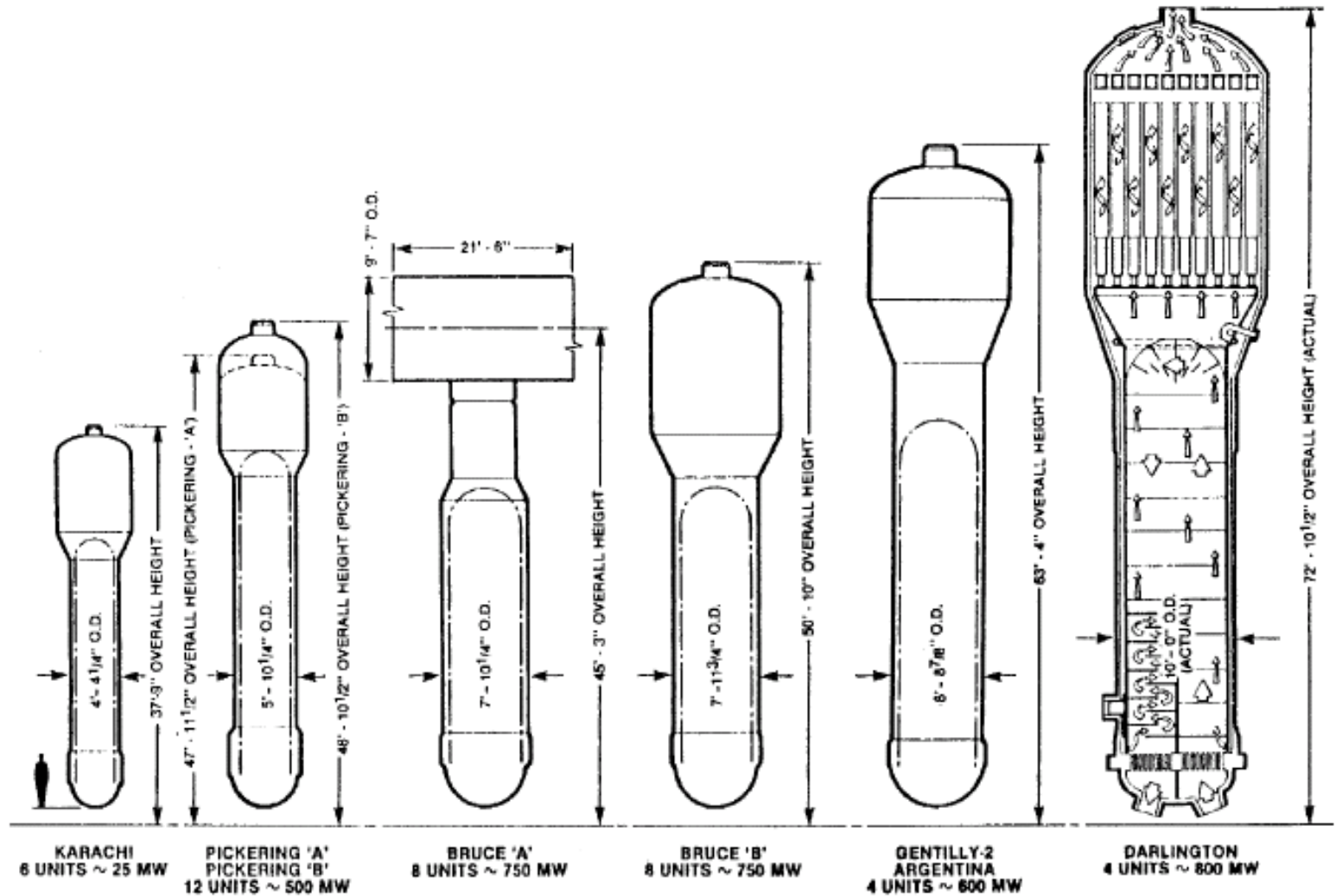

TH Design Evolution

■ Reactor core

- Large increase in core rating
- Reduction in shop fabrication costs
- Reduction of field assembly cost and schedule
- Modularization of components
- Pressure tube diameter increased
- Number of fuel elements in the bundle increased
- Fuel linear power rate increased from 25 kW/m to 50 kW/m
- Channel pitch decreased (C-6 to ACR-700), and slightly increased (ACR-700 to ACR-1000)

TH Design Evolution

Table 8.5 Heavy Water in Core per MW Thermal

	<u>M³/MWt</u>
NPD	.410
Douglas Point	.169
KANUPP	.182
Pickering A	.157
Bruce A & B	.112
Gentilly-2	.105

TH Design Evolution

Table 8.6 MW Thermal per Meter Length of Fuel Channel

	<u>MWt/m</u>
NPD	.163
Douglas Point	.453
KANUPP	.443
Pickering A	.752
Bruce A & B	.881
Gentilly-2	.931

TH Design Evolution

	NPD 1962	DOUGLAS POINT 1967	PICKERING 1971	BRUCE 1976	GENTILLY 1981	950 MW 1987
Output (MWe)	22	210	515	750	630	1030
No. of Fuel Channels	132	306	390	480	380	600
Heavy Water $m^3/MW(t)$	0.41	0.17	0.16	0.12	0.1	0.1
Power MW(t)/m	0.16	0.45	0.75	0.9	0.9	0.9
No. of Steam Generators/ MW(e)/SG		80/25	12/45	8/95	4/160	8/125
No. of Pumps/HP		10(8)/800	16(12)/1600	4(4)/12000	4(4)/9000	4(4)/16000
Non Welded Joints	4000	3000	1000	250	200	200
Valves - Packed/Bellows	1500/0	2000/0	175/570	75/500	90/300	90/300

TH Design Evolution

Steam Generators

	<u>DPNGS</u>	<u>PICKERING A</u>	<u>BRUCE A</u>	<u>GENTILLY-2</u>
Power MW(e)/boiler	2.5	45	95	150
No. of Boilers	80	12	8	4
Tubesheet Diameter	10"/14"	5'-8 1/4"	8'-3 1/8"	9'-1"
Tubesheet Thickness	3 1/8"-4 1/2"	11 1/16"	14 1/4"	15 3/8"
Tube Size OD/Wall	0.496"/0.049"	0.496"/0.049"	0.51"/0.0455"	0.625"/0.0455"
Material	M-400	M-400	I-600	I-800
No. of Tubes	196	2600	4200	3550
Steam Drum Diameter	5' 6"	8'-2 3/8"	11'-8 1/4"	13'-1 3/4"
Shell Thickness	1/2"	1.625"	2.25"	1.943"
Overall Height	32'	46' 7"	50' 10 5/16"	63' 4 1/4"
Overall weight (dry)		185,000 lb	320,000 lb	420,000 lb
Heating Surface Area	11,190 ft ²	20,000 ft ²	26,000 ft ²	34,200 ft ²
Recirculation Ratios	3.71	5.5:1	5.4:1	5:1

TH Design Evolution - Pumps

<u>STATION</u>	<u>DOUGLAS POINT</u>	<u>PICKERING</u>	<u>BRUCE A</u>	<u>GENTILLY-2</u>
Pump Type	Vertical Centrifugal Single Stage	Vertical Centrifugal Single Stage	Vertical Centrifugal Single Stage	Vertical Centrifugal Single stage
Head m (ft)	143 (469)	146 (480)	213 (700)	215 (705)
Flow m ³ /sec (lgpm)	0.43 (5670)	0.77 (10,100)	3.307 (43,600)	2.23 (29,400)
Power per Pump kw (hp)	600 (800)	1170 (1560)	8250 (11,000)	5250 (7000)
Discharge MPa Pressure (psia)	9.577 @ 249°C (1389 @ 480°F)	9.715 @ 249°C (1409 @ 480°F)	10.625 @ 265°C (1541 @ 509°F)	11.342 @ 266°C (1645 @ 512°F)
Number of Pumps operating per reactor	8	12	4	4
Speed (rpm)	1800	1800	1800	1800

TH Design Evolution - Pumps

	<u>DOUGLAS POINT</u>	<u>PICKERING</u>	<u>BRUCE 'A'</u>	<u>GENTILLY-2</u>	<u>POINT LEPREAU</u>	<u>BRUCE 'B'</u>
ASME CODE	Sect.VIII	Sect.VIII	Preliminary Sect.III Cl.1 1969	Sect.III Class 1	Sect.III Class 1	Sect.III Class 1
VOLUME MATERIAL	SA-216-WCB	SA-216-WCB	SA-216-WCB	SA-216-WCC	SA-216-WCC	SA-216-WCC
FLYWHEEL	Solid in Motor	Solid in Motor	Solid in Motor	Solid in Motor	Rotor Laminations	Rotor Laminations
ROTATIONAL INERTIA (lb-ft ²)	7,000	15,000	50,000	30,000	30,000	50,000
SEISMIC CLASSIFICATION	None	None	None	D.B.E. Cat.'A'	D.B.E. Cat.'A'	D.B.E. Cat.'A'
PUMP BEARINGS	Hydro- dynamic Carbon	Hydro- dynamic Carbon	Hydro- static D2O Energized	Hydro- static D2O Energized	Hydro- static D2O Energized	Hydro- static D2O Energized
MOTOR BEARINGS	Oil Lubri- cated Tilting Pad Type	Oil Lubri- cated Tilting Pad Type	Oil Lubri- cated Tilting Pad Type	Oil Lubri- cated Tilting Pad Type	Oil Lubri- cated Tilting Pad Type	Oil Lubri- cated Tilting Pad Type

TH Design Evolution

■ Radiation Exposure Reduction

■ Factors affecting exposure

- Amount of equipment
- Frequency of failure
- Time period required to repair, service, inspect
- Radiation conditions (field and airborne concentrations)

■ Layout improvements – design steps

- Eliminate equipment
- Simplify equipment
- Improve reliability of equipment
- Eliminate materials that lead in high radioactivity
- Better chemical control and purification
- Extend period between maintenance periods
- Provide adequate shielding to enhance accessibility

NPD HTS Schematic

- 132 channels
- 66 inlet and 66 outlet feeders
- Bi-directional channel flow
- Orificing used to match radial power variation
- Two core regions: central with 19-el bundles and outer with 7-el bundles
- Horizontal 'U' tube horizontal steam generator

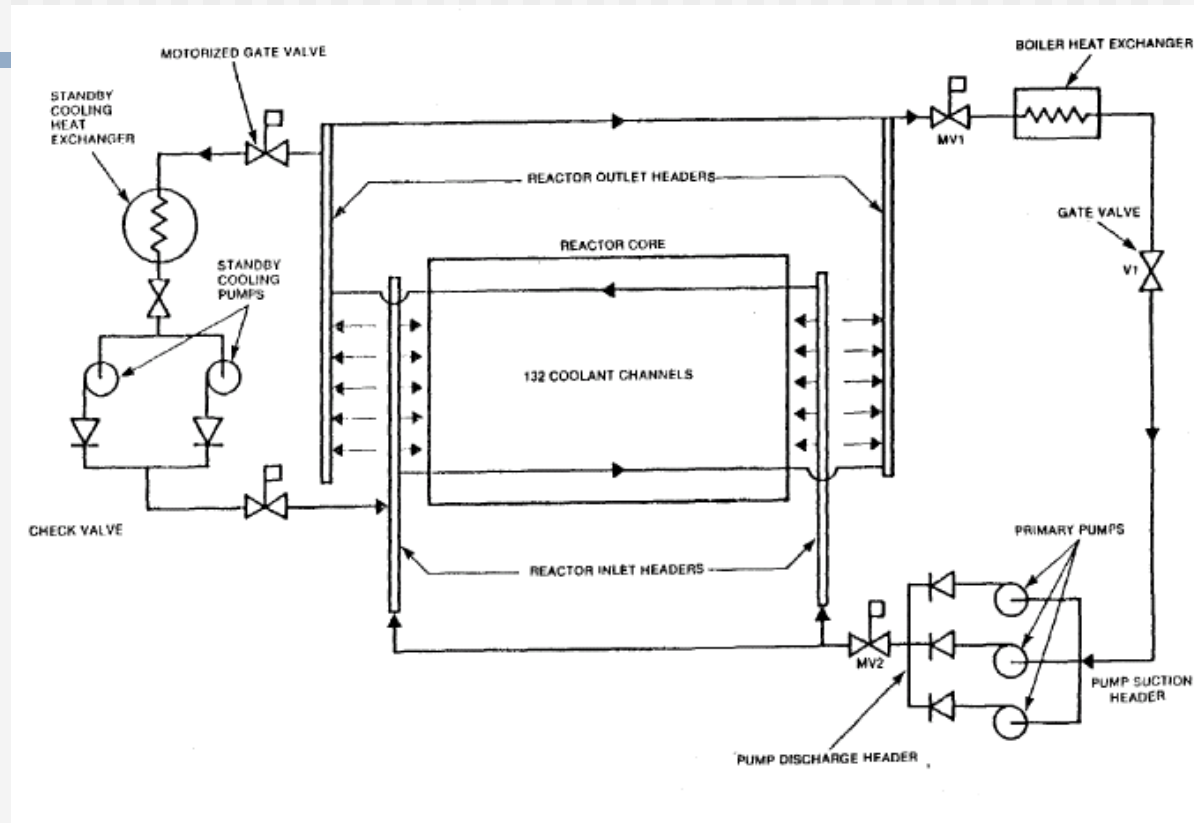

Douglas Point HTS Schematic

- First single 'figure-of-eight' concept
- Long piping runs avoided
- Bi-directional flow
- Check valves at pump discharge
- Orifices to match flow to power variation

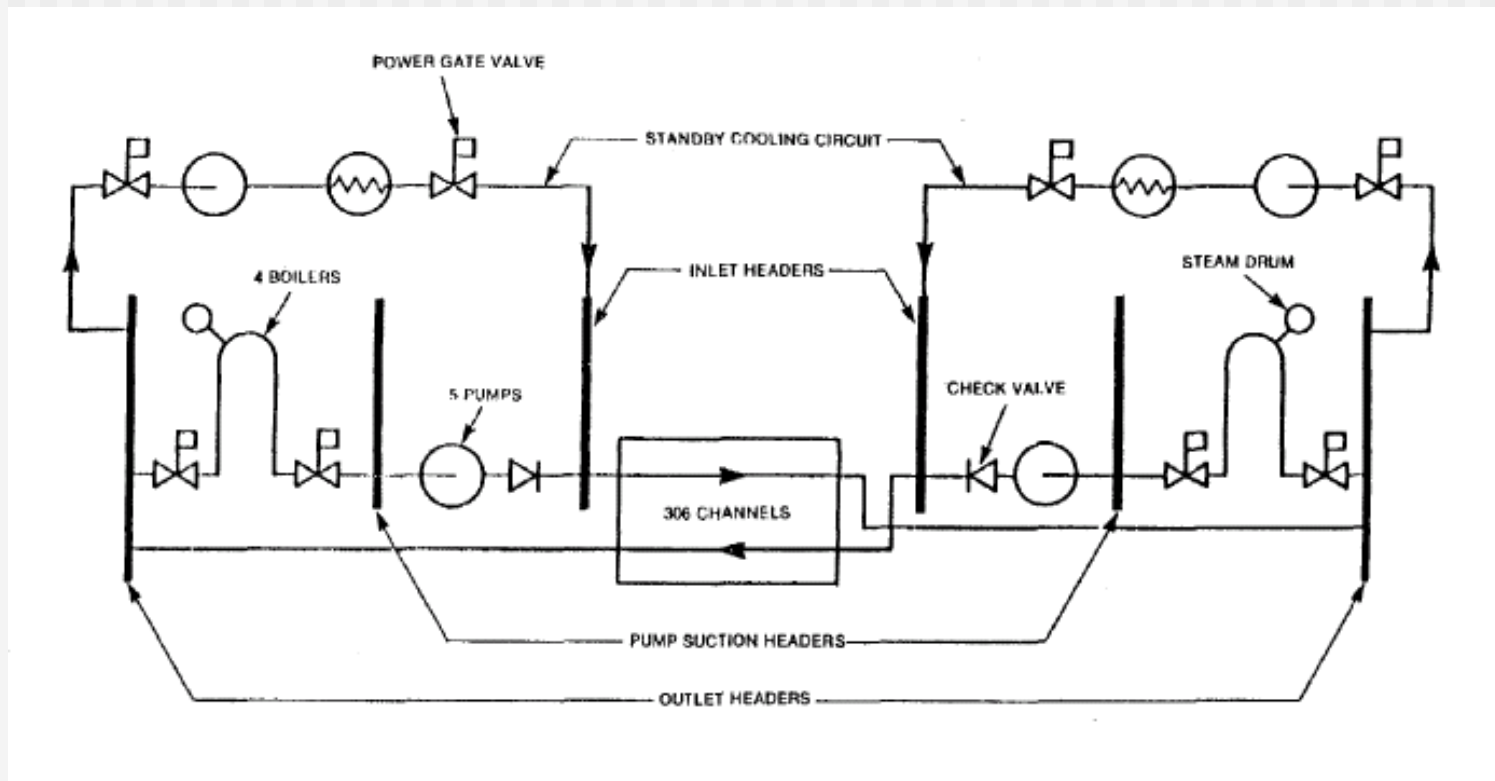

Pickering HTS Schematic

- Double 'figure-of-eight' configuration
- Loop interconnect for pressure balance
- 12 operating pumps and 4 spare pumps
- Orifices used to match flow to power variation

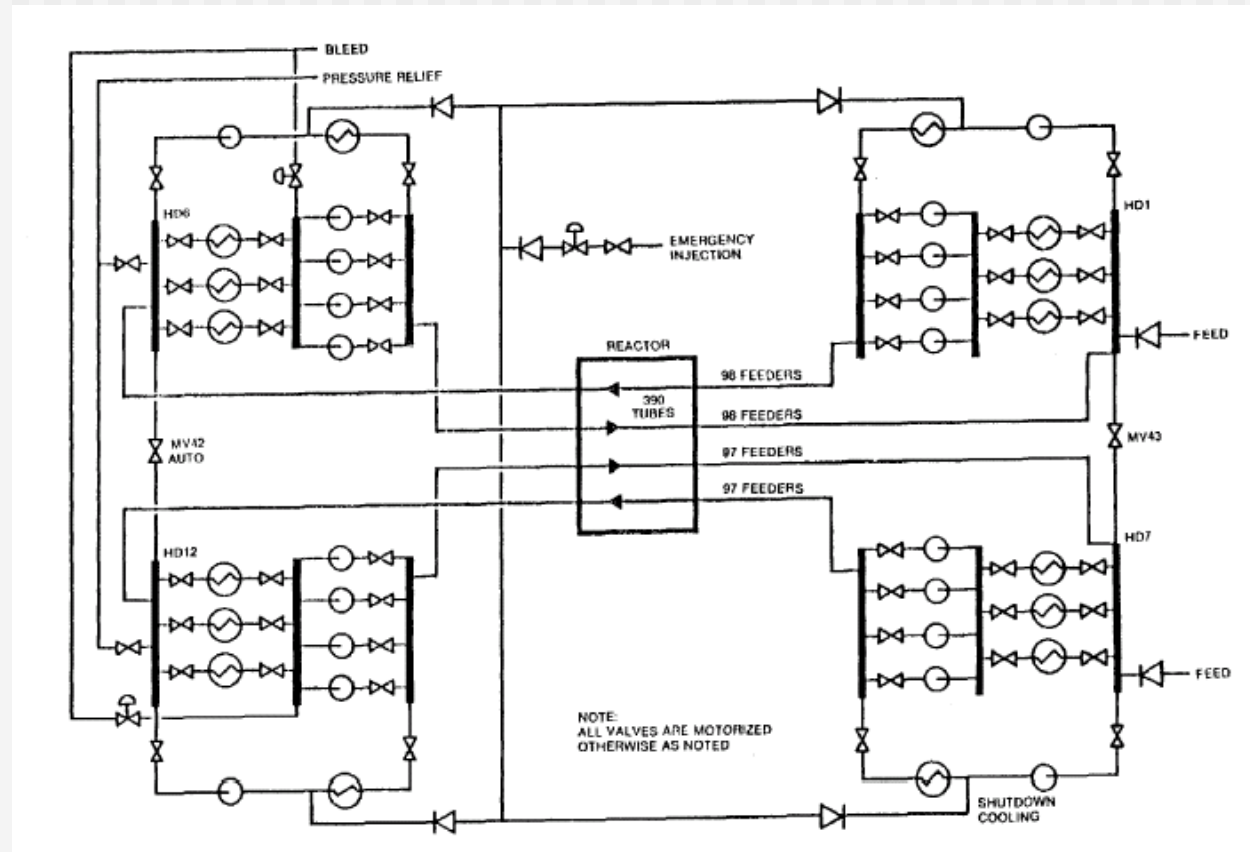

Bruce HTS Schematic

- Standby pumps eliminated
- Valves eliminated
- 8 steam generators, 4 pumps
- 4 inlet headers, 2 outlet headers
- Radial flow variation achieved by different feeder sizes

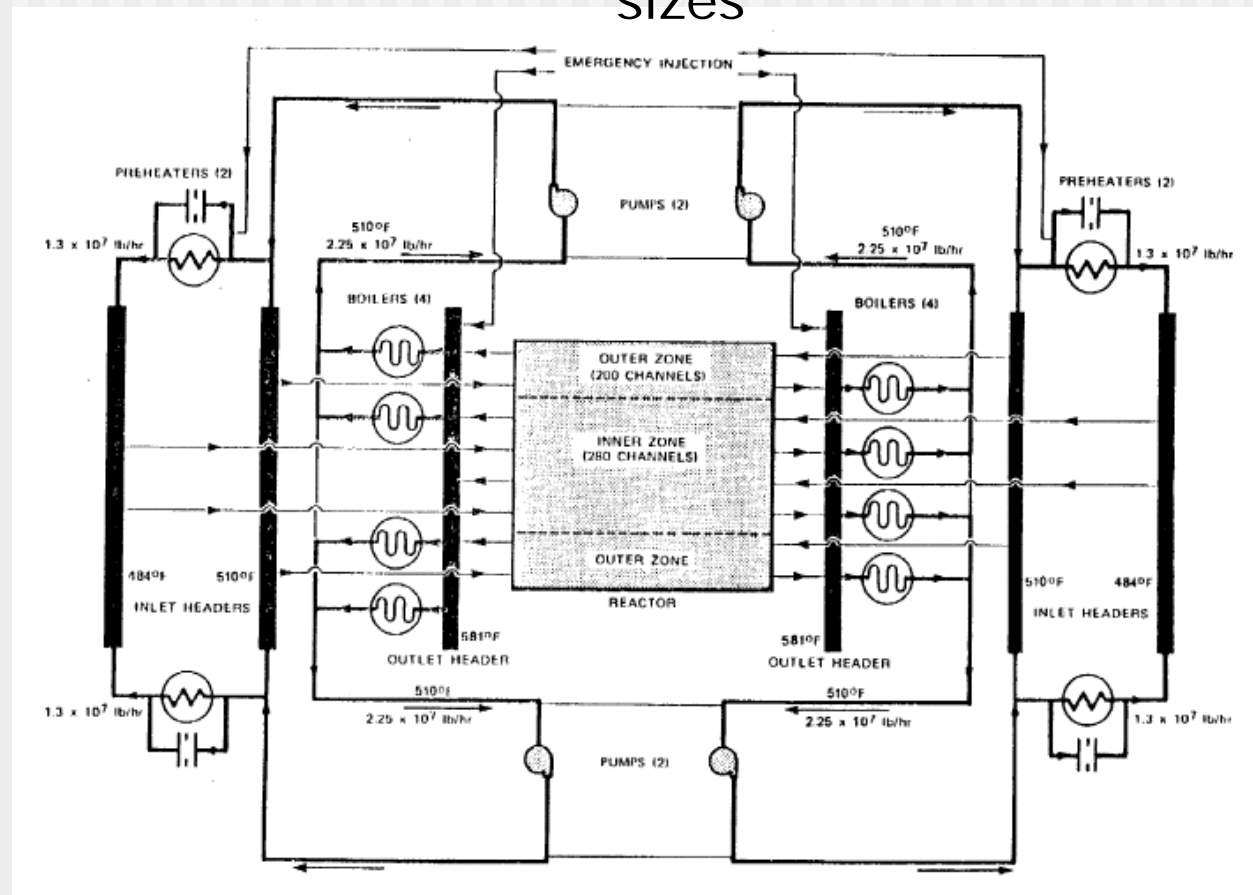

CANDU 6 HTS Schematic

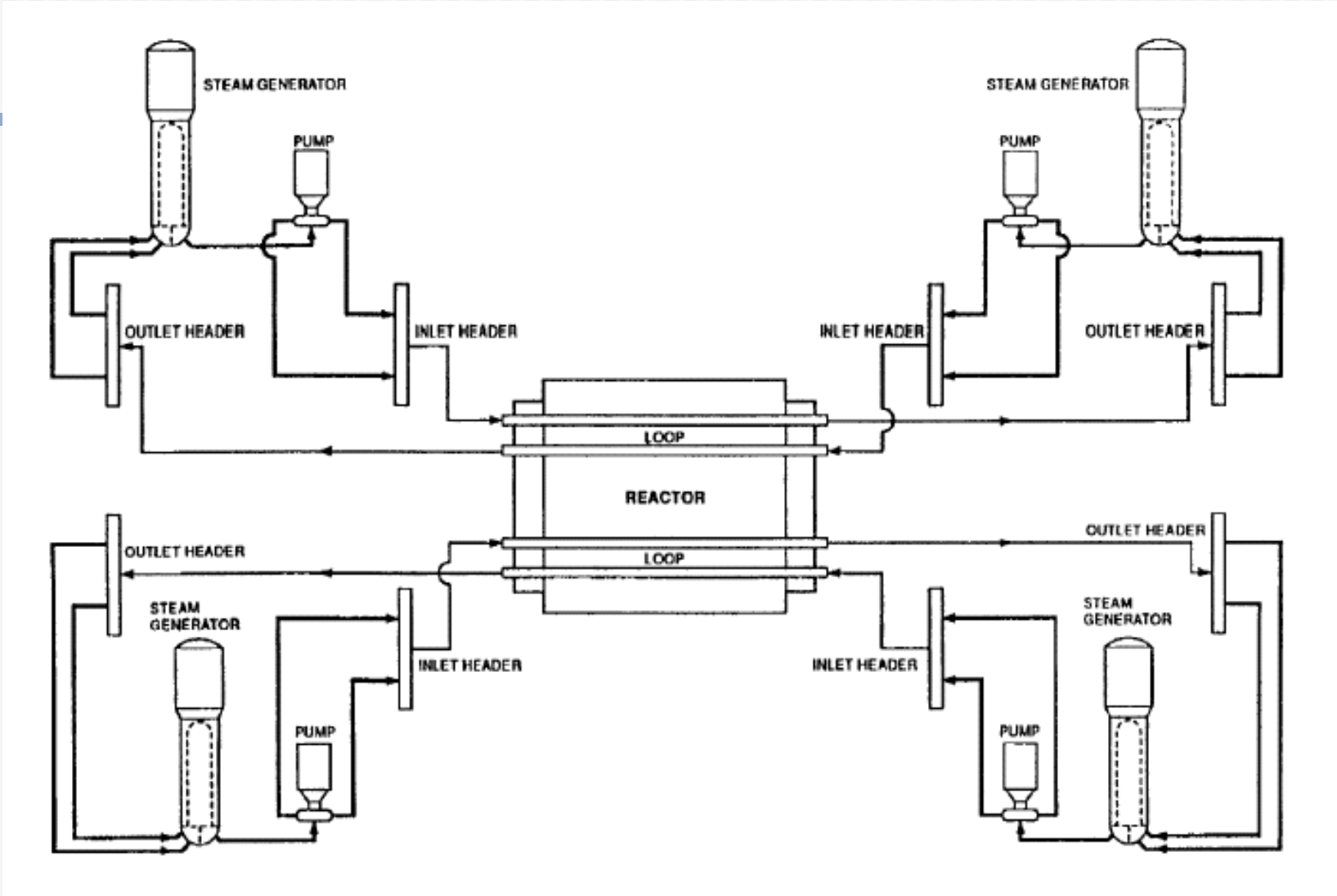

CANDU 9 HTS Schematic

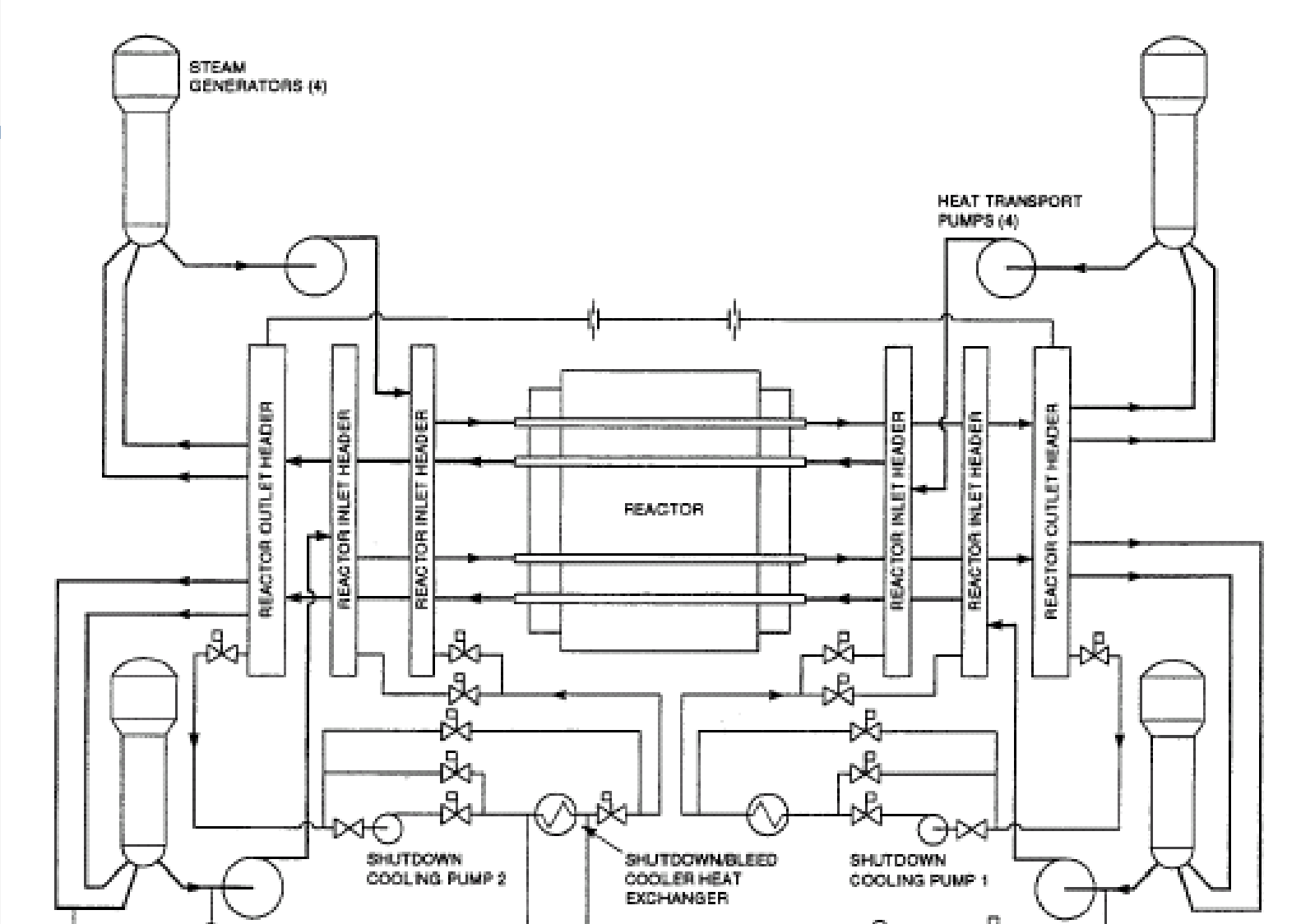

ACR-700 Advanced CANDU HTS Schematic

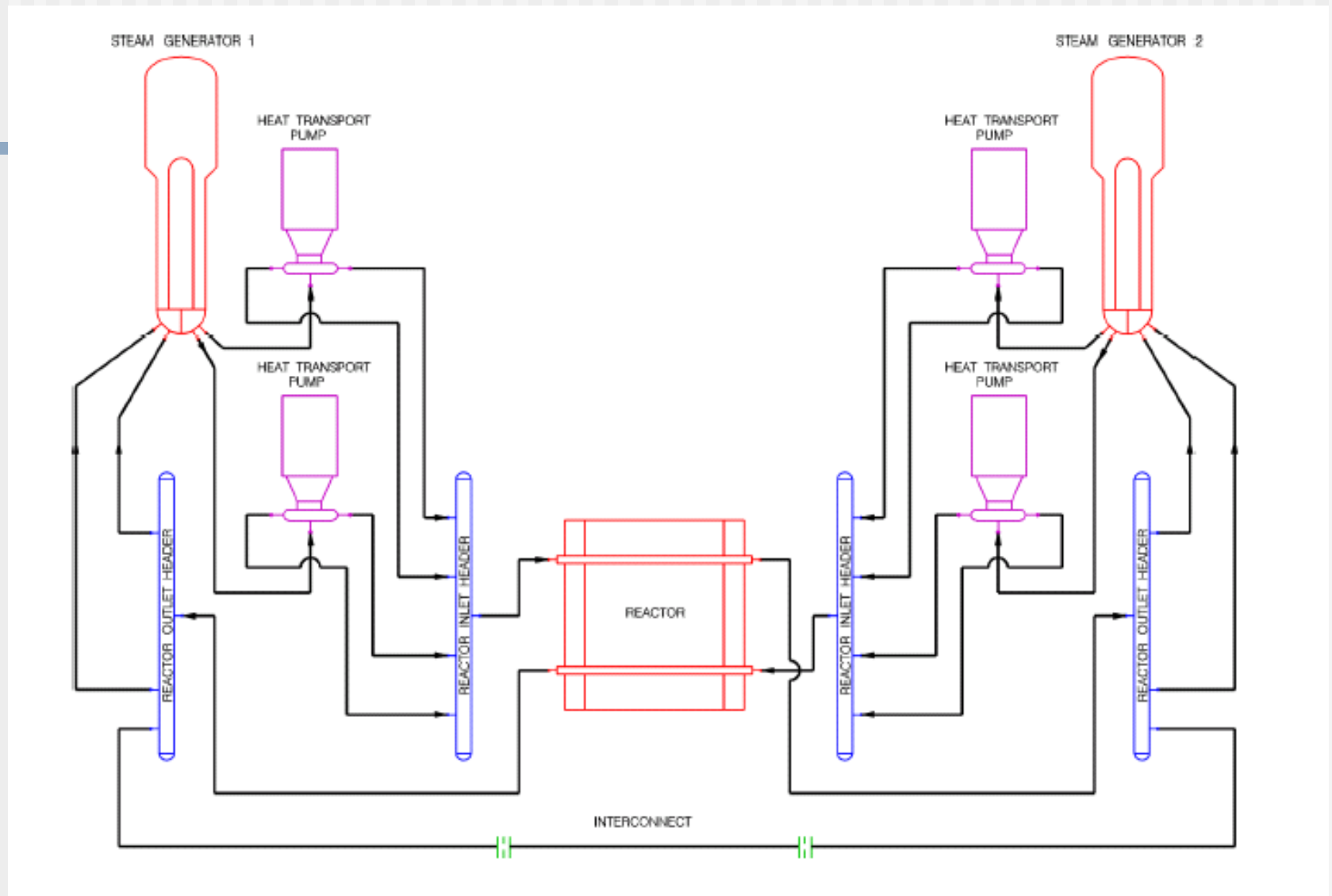

ACR-1000 Advanced CANDU HTS Schematic

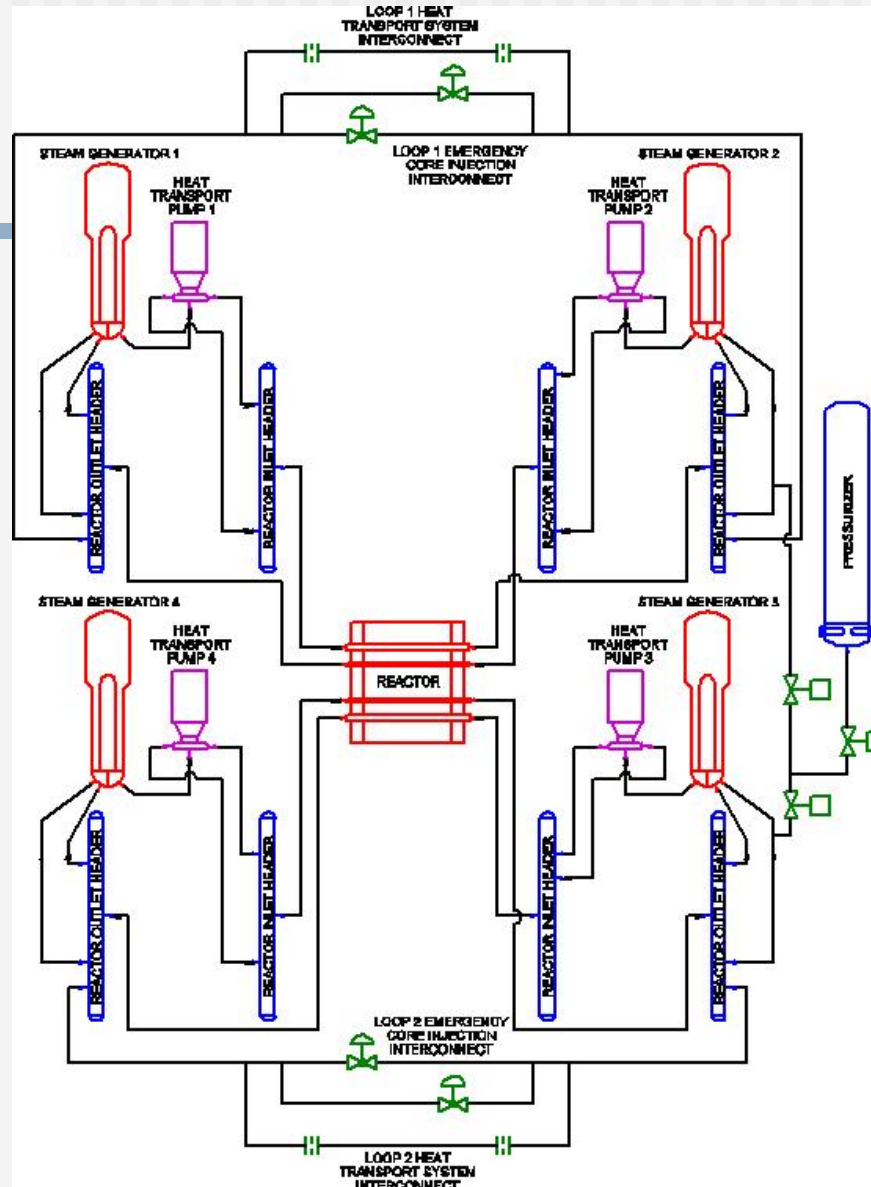

Questions?
