

UNENE Graduate Course Reactor Thermal-Hydraulics Design

McMaster University

Whitby

March 1-2, March 15-16,
April 5-6, April 19, 2008

ACR-700 – CANDU 6 Comparison

Dr. Nik Popov

CANDU Intrinsic Design Features

ACR is an evolutionary extension of the CANDU 6 Design

Retained CANDU features:

- Channel reactor
 - **Horizontal channels**
 - **Pressure tube as core pressure boundary**
 - **Water cooled**
 - **Water moderated**
- Separation of coolant and moderator
- Short fuel bundles replaceable on power

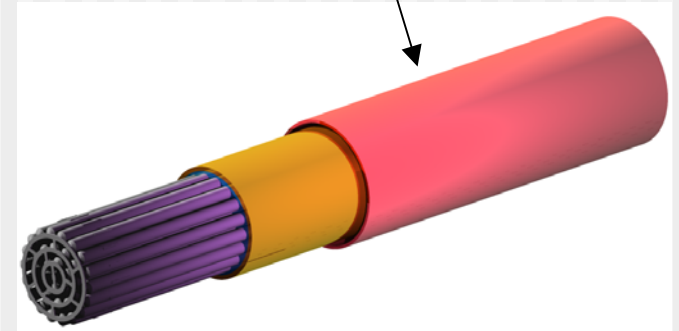
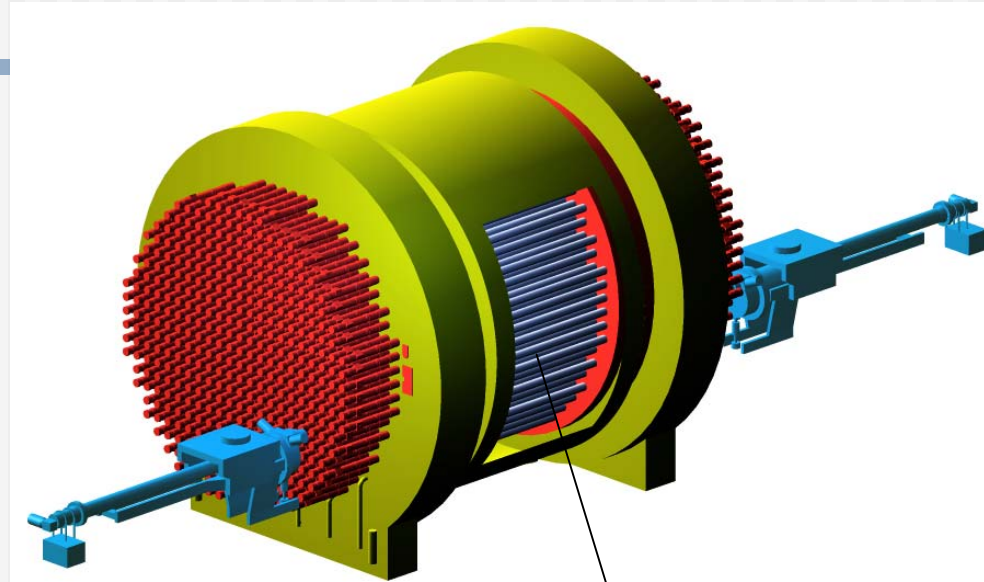

Comparison of CANDU 6 and ACR-700 Lattices

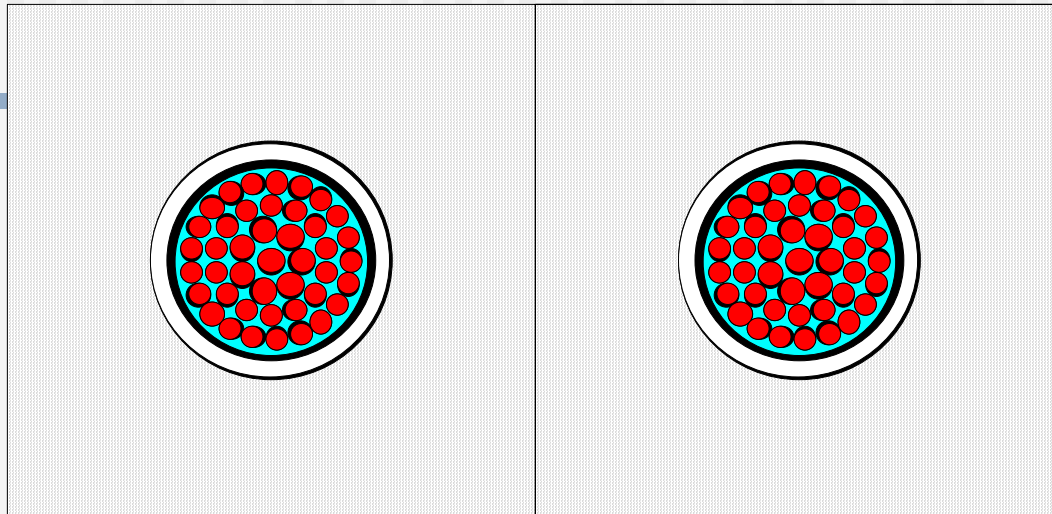

**CANDU 6 Lattice: 286 mm
(11.26")**

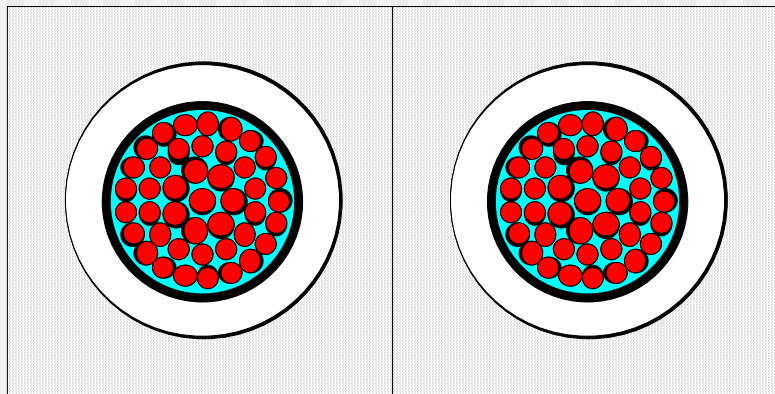

**ACR Lattice: 220 mm
(8.66")**

Core Size Comparison

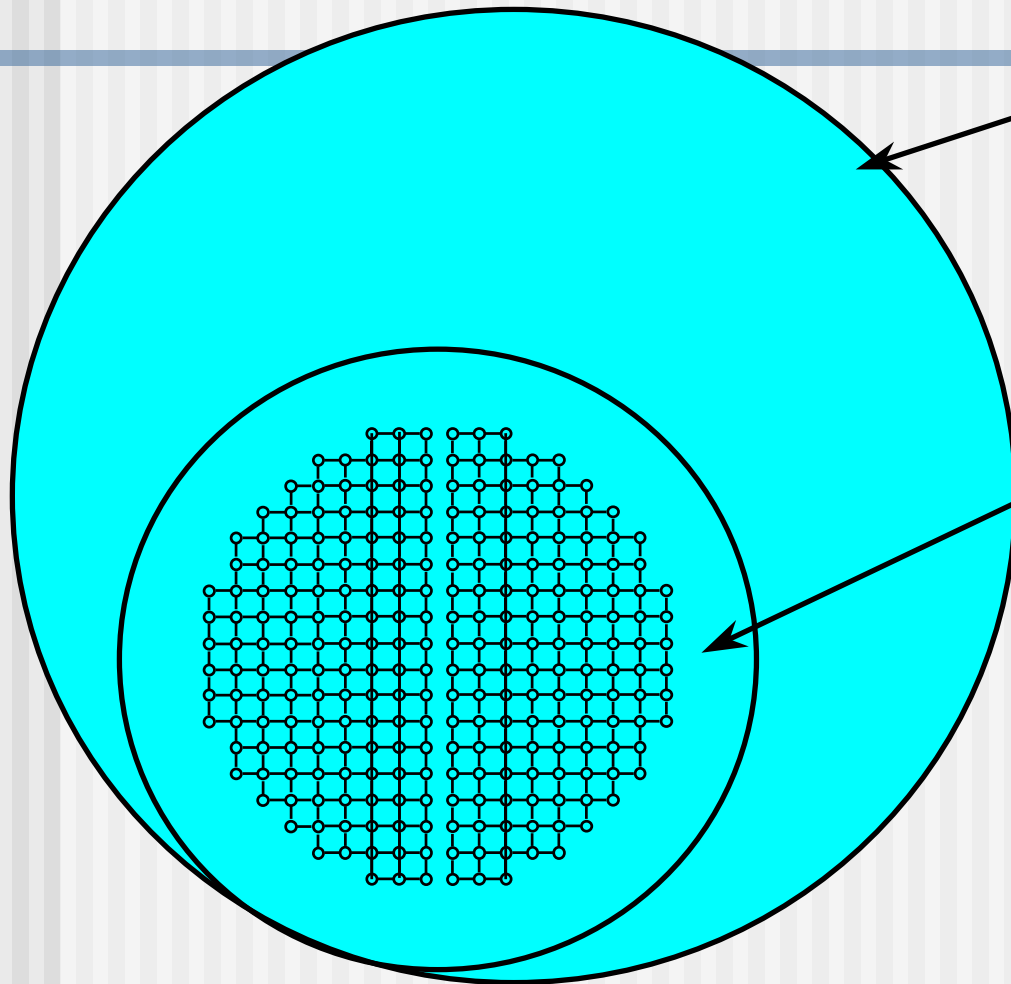

CANDU 6

728 MWe

380 channels

Diameter = 760 cm (~25 ft)

ACR

731 MWe

284 channels

Diameter = 520 cm (17 ft)

Calandria volume reduced by a factor of 2.5 (tight lattice pitch).

By using H₂O coolant, less than 25% of D₂O used in C6 is required.

Core Design

CANDU 6

- Calandria 7.6 m (~25 ft) internal diameter
- 380 fuel channels to give a gross output > 700 MWe.

ACR-700

- Calandria 5.2 m (17 ft) internal diameter.
- 284 fuel channels to give a gross output > 700 MWe.
- D₂O inventory < 25% of CANDU-6 (reduced by using H₂O coolant and smaller D₂O moderator volume).
- Fewer reactivity mechanisms.
- Enhanced reactor control.

Fuel - LOU in ACR CANFLEX bundles

CANDU 6

- Natural Uranium (NU) fuel
- 37-rod, 0.5 m long bundles

ACR-700

- Low Enriched Uranium (SEU) fuel allows flexibility in the value of Coolant Void Reactivity
- 43-rod, 0.5 m long CANFLEX bundle
- NU + 7.5% dysprosium in central pin
- Higher burn-up, higher bundle power, lower rod rating

Fuel Channels (end view)

CANDU 6

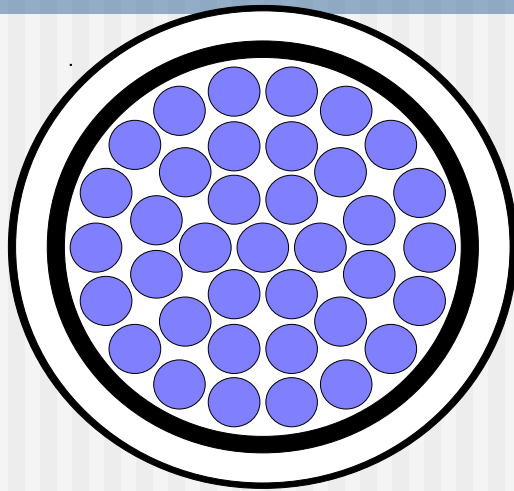

- Zr – 2.5% Nb pressure tube
- Zr-2 calandria tube
- Insulating gap between pressure tube and calandria tube

ACR-700

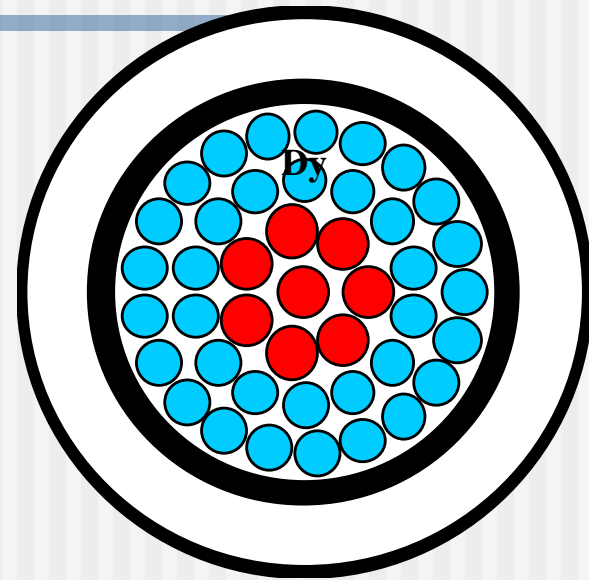

- Thicker Zr – 2.5% Nb pressure tube
- Stronger Zr-4 calandria tube
- Larger gap between pressure tube and calandria tube

Reactivity

CANDU 6

- Positive coolant void reactivity (CVR) +15 mk
- Power coefficient
~ 0 mk / % power

ACR-700

- Negative coolant void reactivity –7 mk
- Negative power coefficient
– 0.07 mk / % power
- All feedback coefficients are negative
- Use of SEU allows flexibility in choice of coolant void reactivity
- Chosen small to increase operating margins related to safety

Reactor Control

CANDU 6

- Liquid zone control supply system which uses light water as the absorber.

ACR-700

- Mechanical zone control designed with solid absorber units to fit reduced space between calandria tubes.
- Solid control absorber units (similar design to C6 with changes to absorbers and guides to fit reduced space)

Reactor Coolant System

CANDU 6

- Heavy water coolant
- Two loops, each with 2 pumps and 2 Steam Generators in series

ACR-700

- Light water coolant
- Single loop with 4 pumps and 2 Steam Generators
- HTS operates at higher pressure and temperature
- Steam generators size similar to range of PWR design

Reactor Coolant System – cont'd

CANDU 6

ACR-700

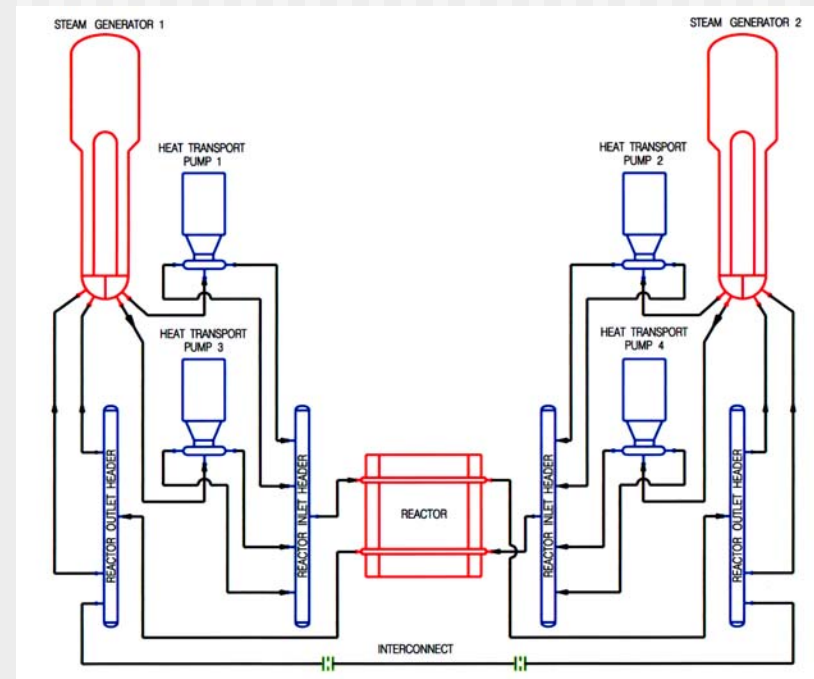
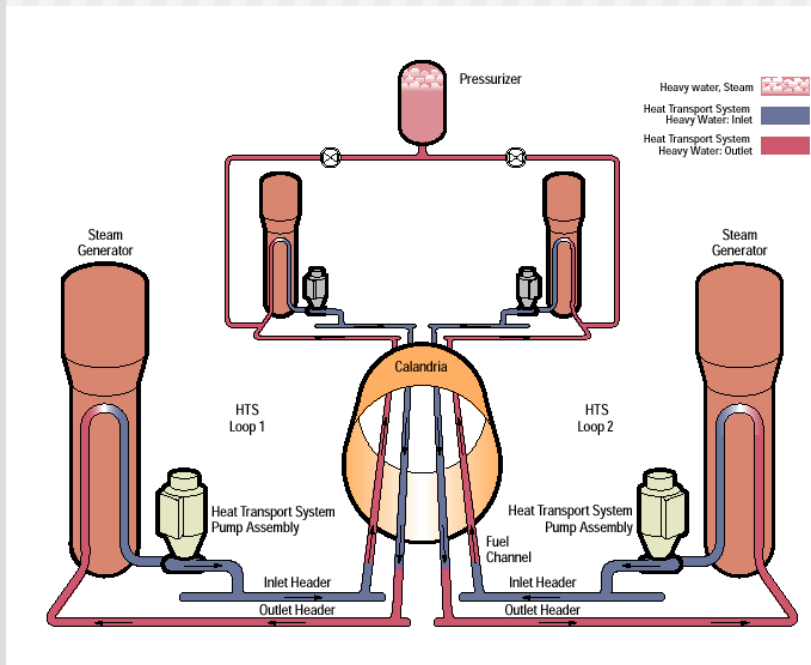

Moderator System

CANDU 6

- 8 x 6" inlet nozzles at horizontal mid plane of calandria
- 2 x 12" outlet nozzles connecting to bottom of calandria

ACR-700

- 12 x 6" inlet nozzles at top section of calandria
- 4 x 10" outlet nozzles at top section of calandria
- Improved inlet nozzle arrangement

CANDU Intrinsic Safety Features

ACR is an evolutionary extension of the CANDU 6 Plant

Retained CANDU features:

- Two fully independent passive shutdown systems:
 - **SDS1 – rods drop by gravity into core**
 - **SDS2 – liquid absorber injected into reflector / moderator by pressurized gas**
- Emergency Core Cooling System
- Containment
- Light water shield tank as back-up heat sink for severe core damage accidents

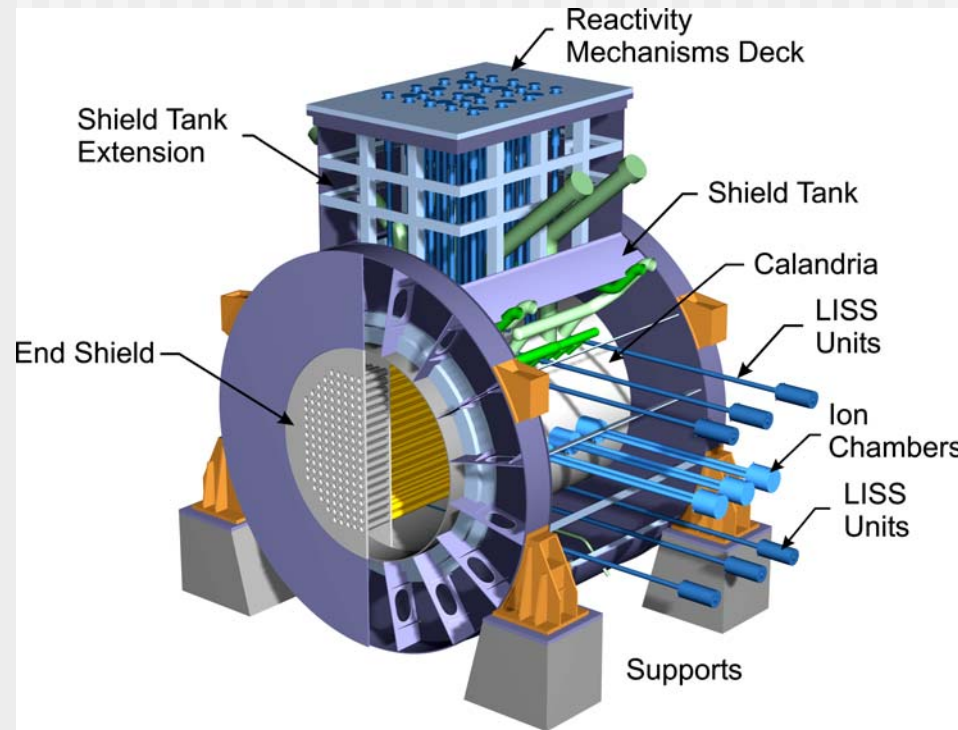

Emergency Core Coolant System

CANDU 6

- Three stages:
 - High pressure – external tanks (includes pressurized gas tank)
 - Medium pressure - dousing tanks
 - Low pressure – building sump
- Injection to all headers
- Long term recirculation at G-2 uses 1 HX and 2 pumps

ACR-700

- Two Stages
 - High pressure - injection from pressurized tanks in containment (pressure maintained by nitrogen gas, i.e. no gas tank)
 - Long Term Cooling (LTC) System for long term pumped recovery
- Injection to inlet headers and a large ROH interconnect is included
- Two divisions of long term cooling – 2 heat exchangers and 4 pumps
- Use of passive one-way rupture discs
- Floating ball shutoffs

Questions?
