

# **STEAM GENERATOR PRESSURE CONTROL**

# REACTOR HEAT REMOVAL

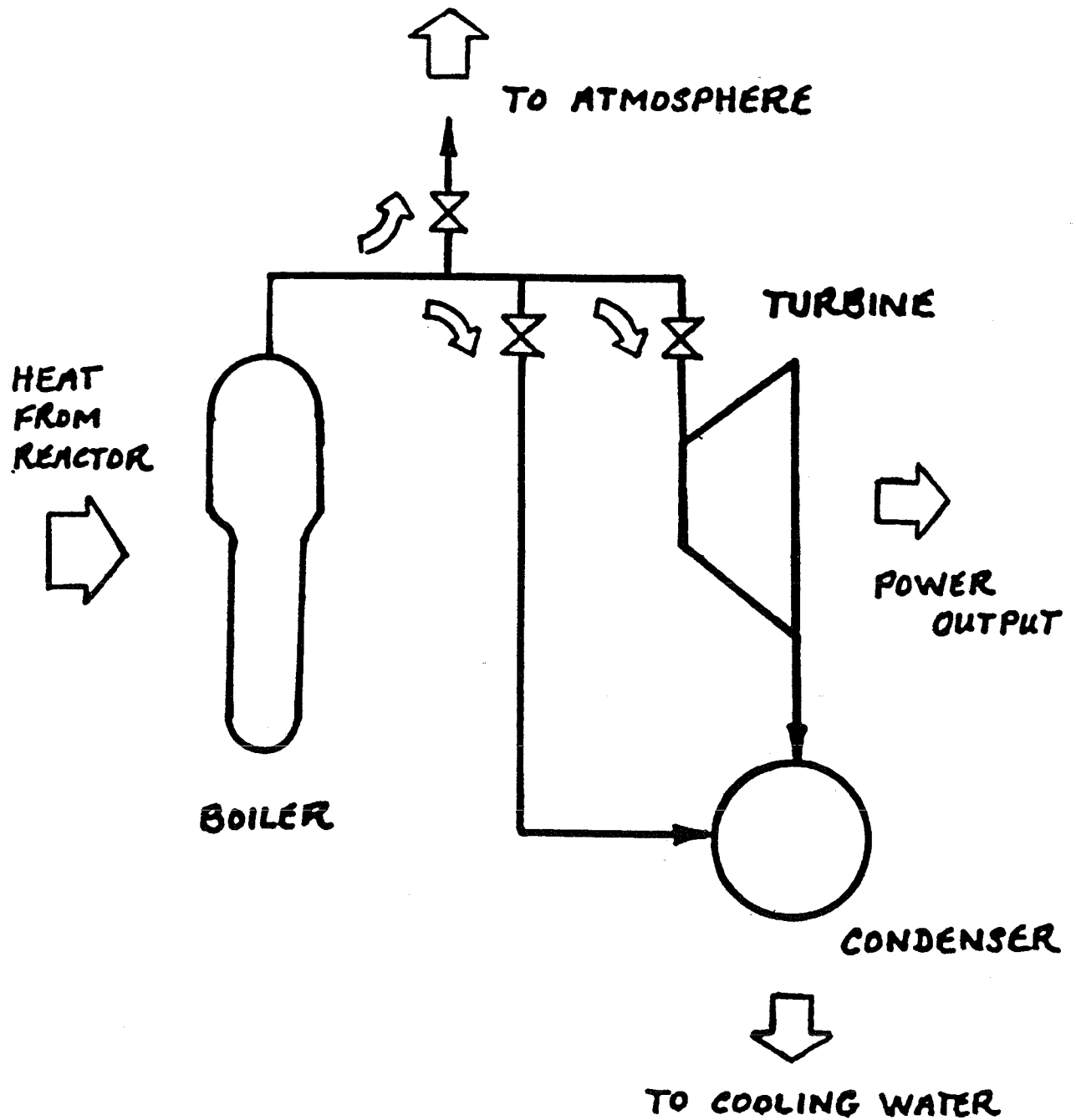

Overhead 3.1 Heat Removal Routes

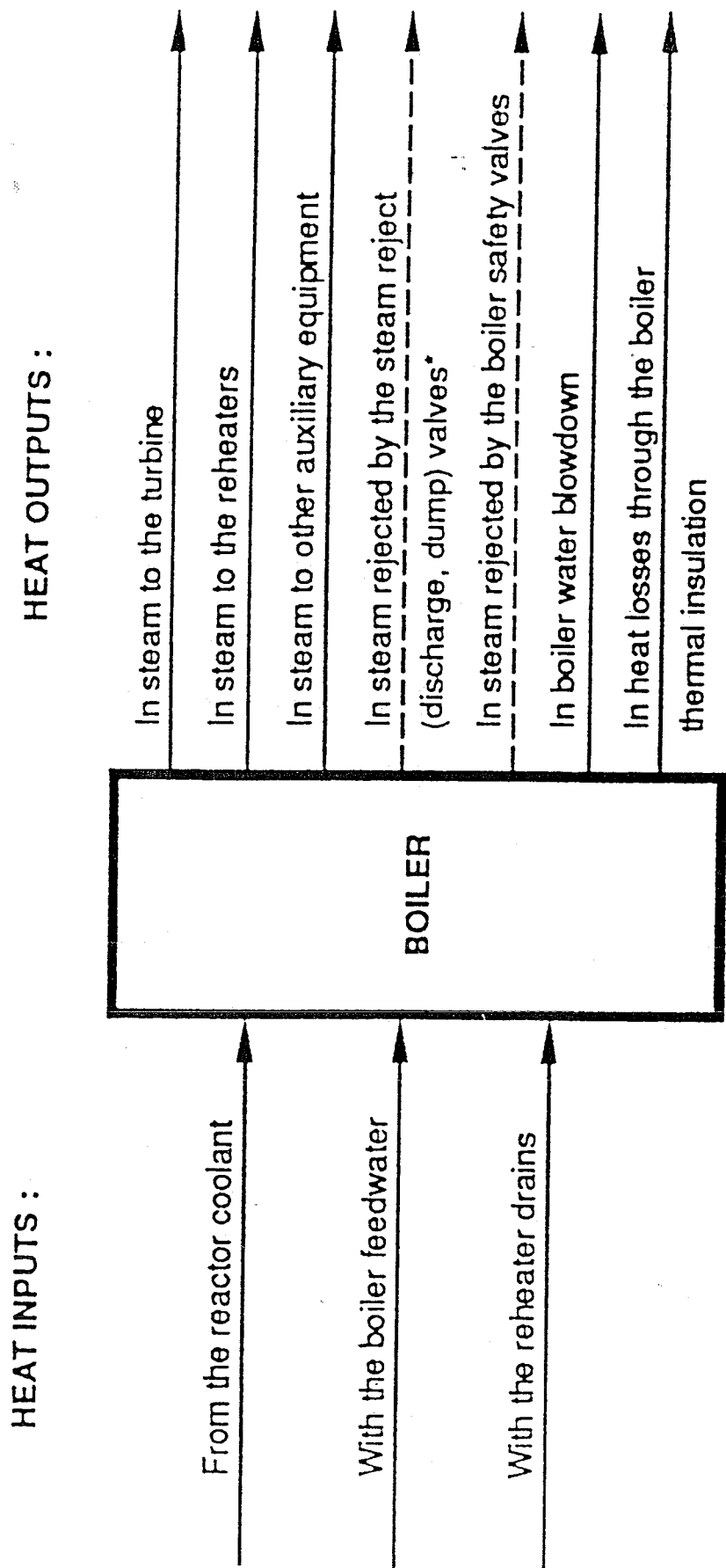

**Fig. 2.1. Heat inputs and outputs in a CANDU boiler:**

# PLANT CONTROL

## REACTOR LEADING

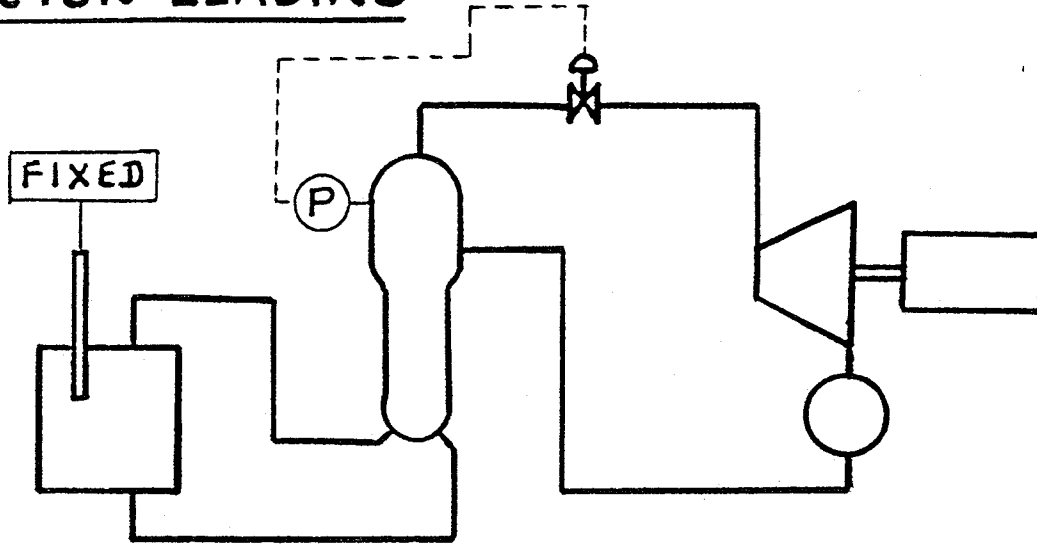

REACTOR POWER CONSTANT

STEAM FLOW VARIED TO  
MAINTAIN STEAM PRESSURE

## REACTOR LAGGING

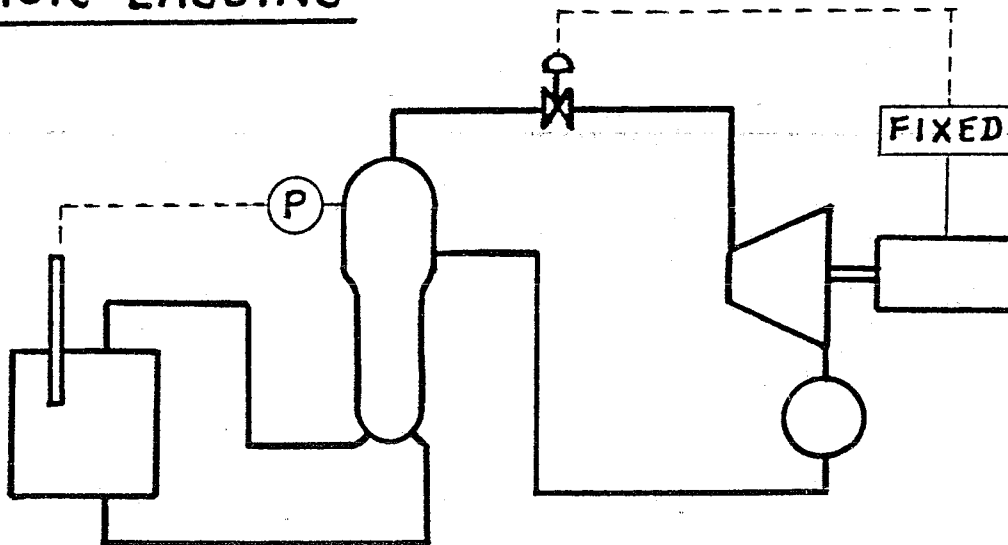

REACTOR POWER VARIED TO  
MAINTAIN STEAM PRESSURE

GENERATOR LOAD CONSTANT

## Normal boiler pressure control

Boiler pressure is normally controlled automatically by a special computer subroutine called **BPC** (short for Boiler Pressure Control). This subroutine is run all the time by the computer that normally controls the unit operation. **BPC** performs two major functions:

### 1. It attempts to maintain boiler pressure at its setpoint.

This is achieved by scanning all boiler pressures in regular intervals \* and initiating some corrective actions when a pressure error is detected or anticipated. The latter applies, for example, to major unit upsets such as turbine trips when it is obvious that boiler pressure will change. As **BPC** begins its corrective action right after the upset has occurred (ie. without waiting for boiler pressure to change), the resultant pressure transient is considerably reduced.

### 2. It changes the boiler pressure setpoint during the following operating states:

- a) Warmup and cooldown of the HT system;
- b) Reactor loading and unloading (except for the stations where the boiler pressure setpoint is kept constant over the whole reactor power range).

In order to keep boiler pressure at its setpoint, **BPC** must try to maintain a proper balance between the boiler heat input and output. This can be achieved by varying either the reactor power (ie. the heat input) or the steam flow out of the boilers (ie. the heat output). This brings us to two modes of the **BPC** operation:

### 1. The reactor lagging mode (also called the turbine leading mode).

In this mode, boiler pressure is controlled by adjusting the reactor power. When a boiler pressure error (defined as the difference between the actual boiler pressure and the setpoint) is detected, the **BPC** adjusts the set-

point to the reactor regulating system. The system then brings reactor power to the new setpoint. Along with the boiler pressure error, the rate at which the turbine steam flow (and hence, the boiler heat output) is changing is monitored, too. This is achieved by measuring the steam pressure at the HP turbine inlet or close to it\*. This extra input allows the BPC to anticipate an upcoming change in boiler pressure and respond to it in advance, thereby minimizing pressure fluctuations.

This is the preferred mode of BPC operation in most CANDU stations. Its names reflect the fact that when this mode of control is used, changes in the reactor power lag behind changes in the turbine generator output.

2. **The reactor leading mode (also called the turbine following mode).**

In this mode, changes in reactor power occur before changes in the boiler steam flow. Reactor power is controlled independently, and **boiler pressure is controlled by adjusting the setpoint to the turbine governing system.** This causes the turbine steam valves to change the boiler steam flow as requested by the BPC. Needless to say, it causes the generator output to change accordingly.

To enhance boiler pressure control when the BPC operates in this mode, some other parameters (in addition to the boiler pressure error) are used as inputs by the BPC. These typically include the rate at which boiler pressure is changing and the rate at which reactor power is changing. Their use allows the BPC to anticipate the upcoming changes in boiler pressure, and hence minimize pressure transients.

This is the preferred mode of BPC operation in some CANDU stations. But in most stations, this is the *alternate* mode which is selected when the preferred reactor lagging mode of operation is not suitable. For example, this happens following a reactor trip, stepback or setback when the reactor power is either lost or cannot be manoeuvred due to some operational problem.

For these situations, we can utilize the general heat transfer equation we established for heat exchangers in module 2:

$$\dot{Q} = U \cdot A \cdot \Delta T_m$$

where:  $\dot{Q}$  = heat transfer rate in the boilers, closely related to reactor thermal power,

$U$  = overall heat transfer coefficient;

$A$  = effective boiler tube surface area, and

$\Delta T_m$  = average D<sub>2</sub>O-to-H<sub>2</sub>O temperature differential in the boilers.

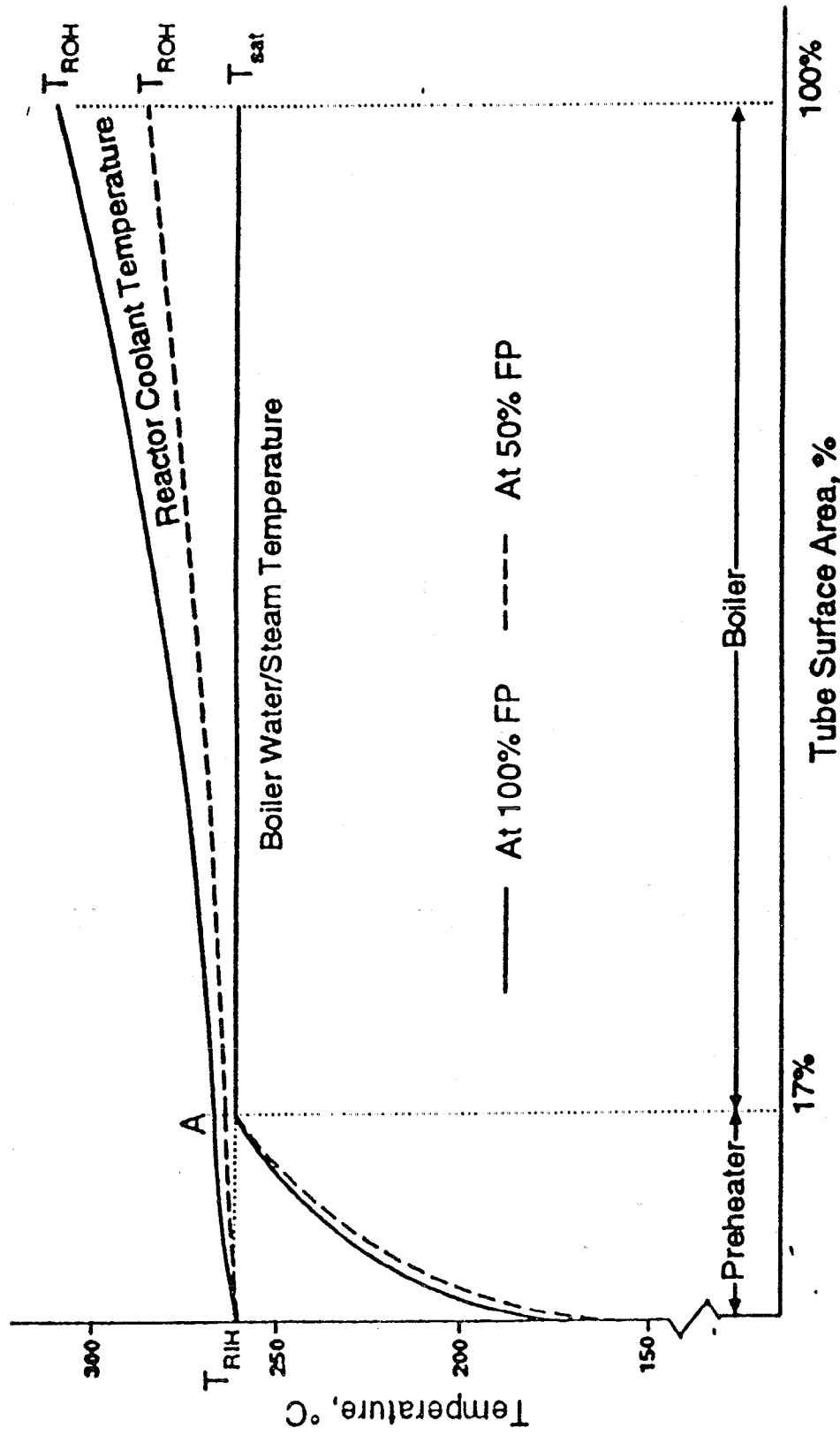
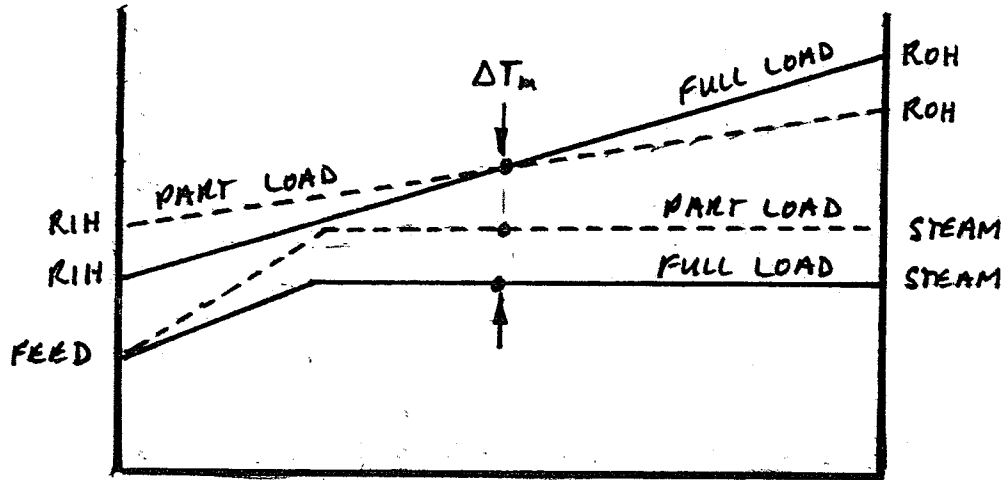

Figure 6.5: Boiler Water and Reactor Coolant Temperature Profile

# CHANGE IN LOAD

## PICKERING (SOLID SYSTEM)



## BRUCE & DARLINGTON (PRESSURISER)

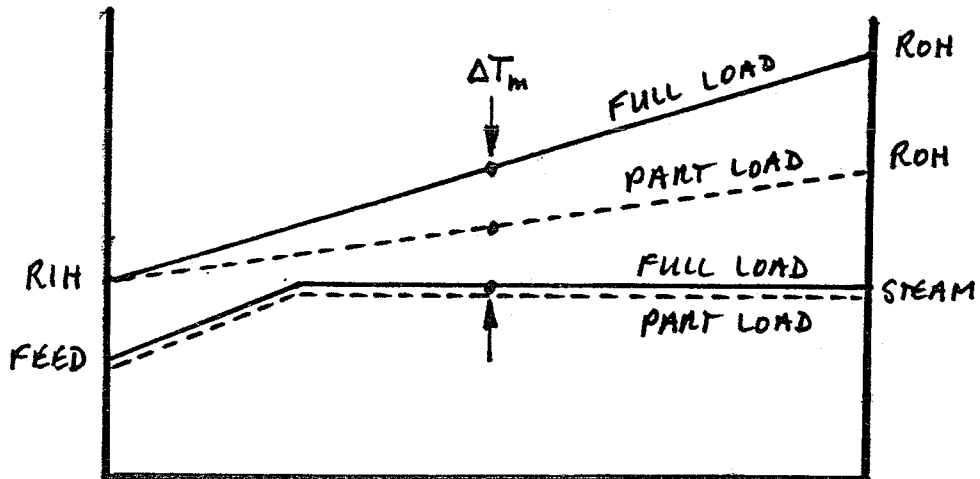

# TRANSIENT CONDITIONS

## WARMUP & LOADING

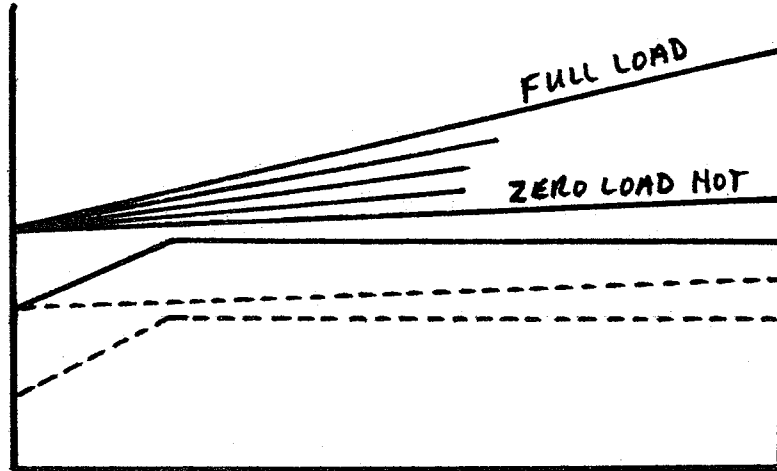

## COOLDOWN

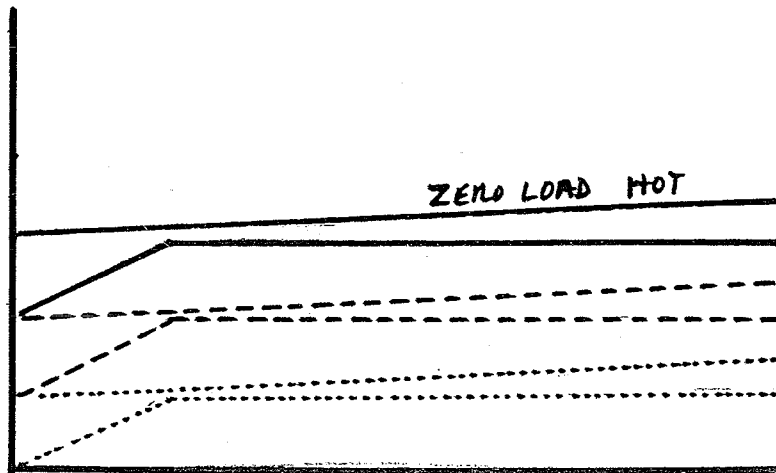

# HEAT TRANSPORT SYSTEM COOLDOWN

## REQUIRED RATE

SLOW ENOUGH TO AVOID THERMAL SHOCK

FAST ENOUGH TO AVOID:

- DELAYED HYDRIDE CRACKING
- DEMIN. WATER LOSSES
- UNIT DOWNTIME

## MINIMUM PRESSURE AND TEMPERATURE

GOVERNED BY :

- VOLUMETRIC FLOW RATE OF VALVES  
(INCREASES WITH DECREASING PRESSURE)
- CONDENSER VACUUM CONDITIONS
  - AUXILIARY STEAM SUPPLY TO TURBINE SEALS & AIR EJECTORS

NOTE THAT CSDV'S ARE PROGRESSIVELY UNLOADED WITH INCREASING CONDENSER PRESSURE

# THERMOSYPHONING

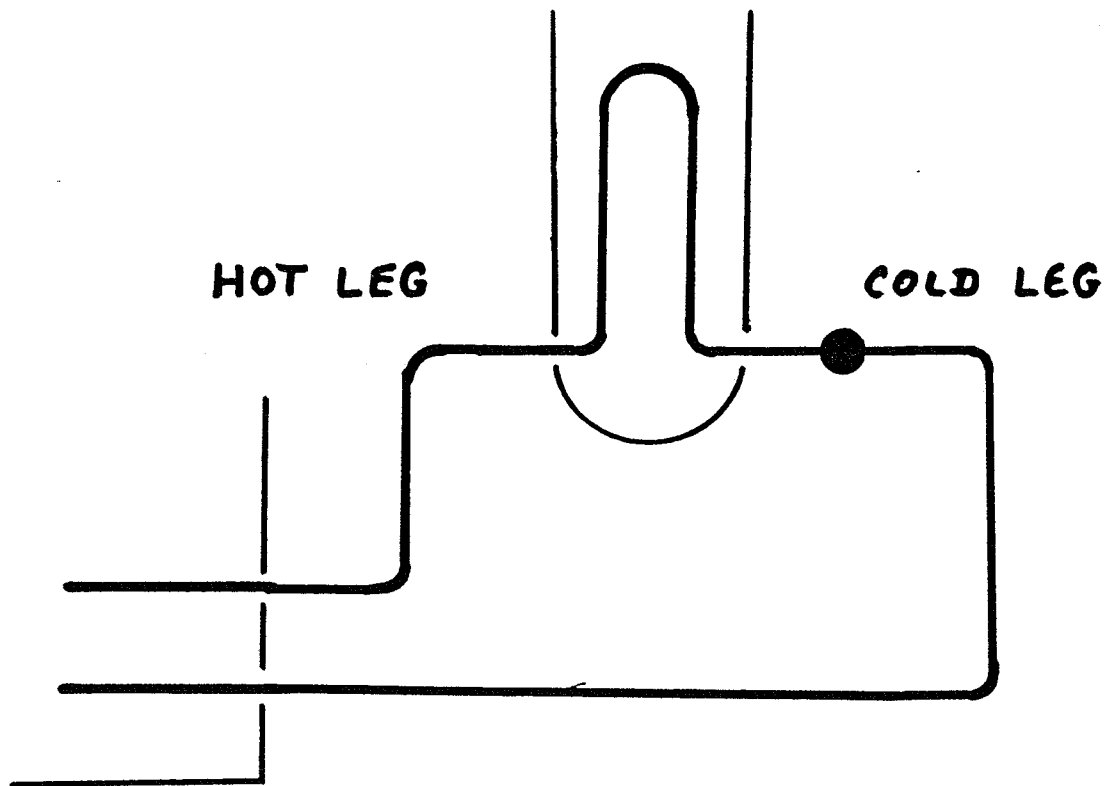

## CONDITIONS FOR THERMOSYPHONING

- STEAM GENERATOR SECONDARY FLUID AT LOWER TEMPERATURE THAN HT SYSTEM FLUID
- NO EXCESSIVE BOILING IN FUEL CHANNELS THAT COULD CAUSE VAPOUR LOCKING

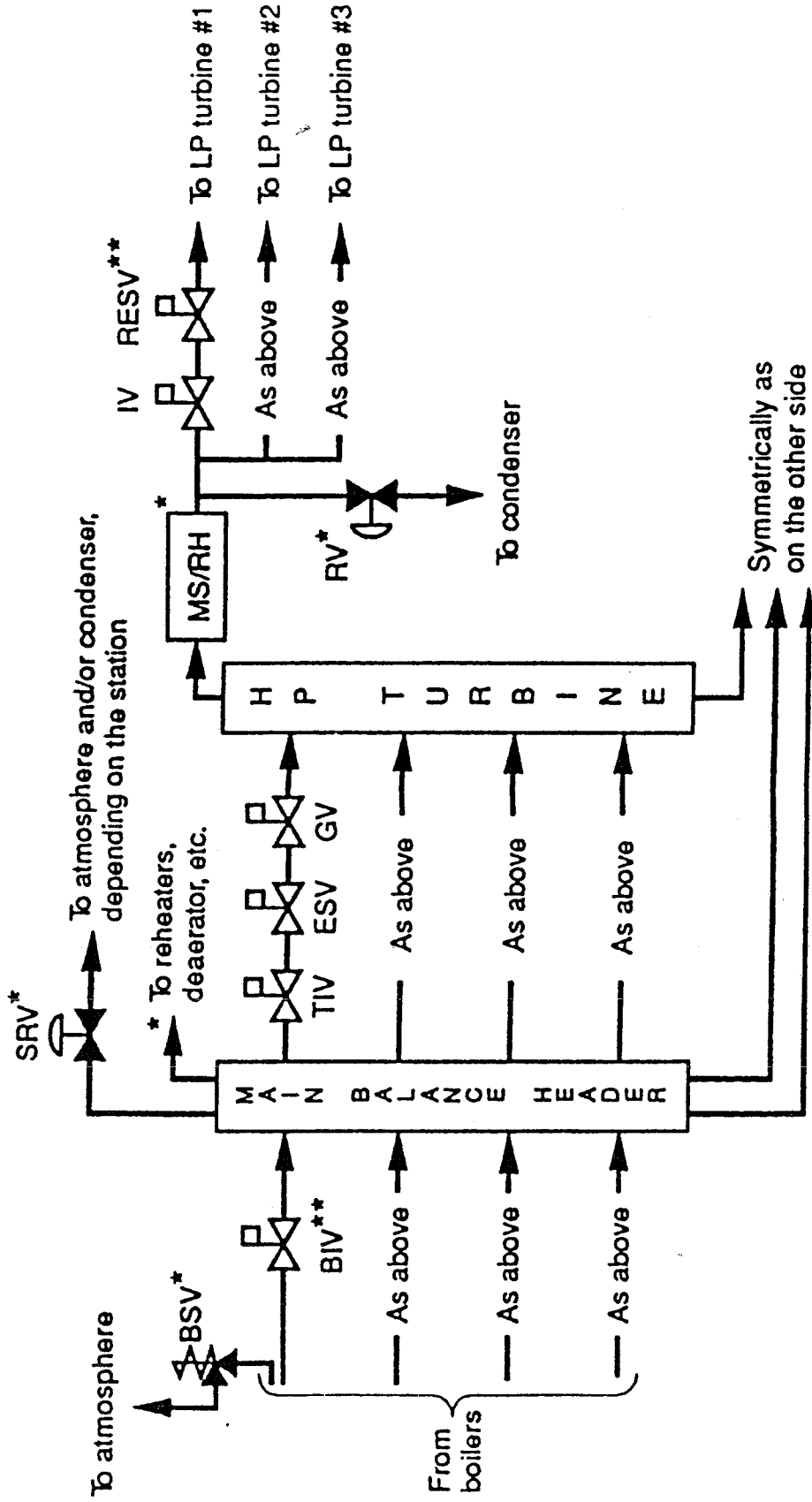

Fig. 3.5. Simplified arrangement of the major steam valves in a typical CANDU unit:

- MS/RH = moisture separators and reheaters. For valve acronyms see the glossary.
- \* The exact number and location of this equipment depend on the station and may differ from those shown.
- \*\* Not in all stations.

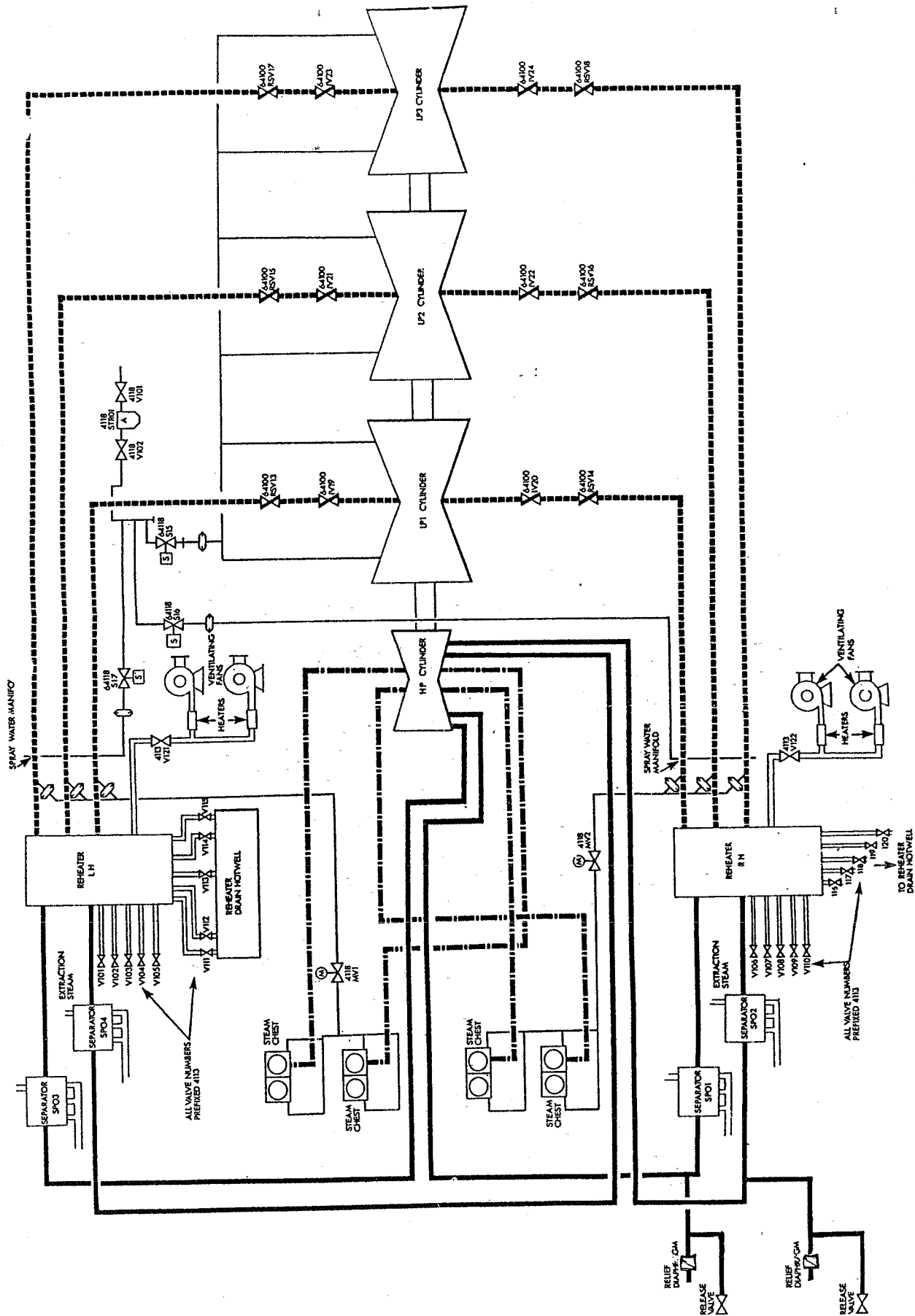

FIG. 6 DIAGRAMMATIC ARRANGEMENT OF STEAM PIPES AND VAI VFC

# **STEAM REJECT VALVES**

## **BOILER SAFETY VALVES**

- 1. OVERPRESSURE PROTECTION**
- 2. CRASH COOLDOWN**

## **STEAM REJECT VALVES (SRV)**

- 1. CONTROLLED COOLDOWN**
- 2. TURBINE TRIP OR LOAD REJECTION**
- 3. UNIT UNLOADING (REACTOR FOLLOWING)**
- 4. UNIT LOADING (REACTOR LEADING)**
- 5. UNIT STARTUP (NOT LIMITED BY TURBINE)**

## **TYPES OF SRV**

**CSDV    CONDENSER STEAM DISCHARGE (DUMP)  
VALVES (65% FULL STEAM FLOW)**

**ASDV    ATMOSPHERIC STEAM DISCHARGE VALVES  
(FULL STEAM FLOW AND CAN BE USED  
FOR CRASH COOLING)**

# **STEAM DISCHARGE VALVES**

## **(CSDV's)**

### **POTENTIAL PROBLEMS**

- \* DAMAGE BY STEAM JETS**
- \* DAMAGE BY WATER INDUCTION**
- \* EXCESSIVE TEMPERATURE GRADIENTS**
- \* OVERHEATING OF EXPANSION JOINT**

### **OPERATIONAL LIMITS**

- 1. CONDENSER VACUUM**
- 2. TURBINE LOAD**

### **CSDV TRIP (INHIBITS OPENING)**

- 1. POOR CONDENSER VACUUM**
- 2. UNAVAILABILITY OF COOLING SPRAYS**
- 3. VERY HIGH BOILER LEVEL**